

CISPI DESIGNATION 310-12

SPECIFICATION FOR COUPLING FOR USE IN CONNECTION WITH HUBLESS CAST IRON SOIL PIPE AND FITTINGS FOR SANITARY AND STORM DRAIN, WASTE, AND VENT PIPING APPLICATIONS.

This specification is issued under the fixed designation 310; the number immediately following the designation indicates the year of original adoption or, in the case of revision, the year of last revision. A number in parentheses indicates the year of last reapproval without change. Specifications for these couplings were originally a part of standard 301-64T. With publication of standard 301-78 for pipe and fittings only, the Institute deleted all specifications for these couplings there from and issued specification 310-78 therefore. Current revision approved March 28, 2012. Last previous edition 310-11. The new revision has been edited to reflect the manufacturer testing requirements for the couplings.

GENERAL INFORMATION

Several different types of hubless couplings are available for use in hubless cast iron sanitary and storm drain, waste and vent piping applications to connect hubless cast iron soil pipe and fittings by using a sleeve-type, or some other type coupling device. It is the purpose of this Designation CISPI 310-12, to furnish information as to the characteristics of one of such sleeve-type couplings and also to furnish suggestions as to the installation of such couplings when applied to cast iron soil pipe and fittings manufactured in accordance with CISPI Designation 301, latest revision. It must be noted that the installation procedures are not a mandatory portion of this Designation 310-12 and the illustrative installation instructions included herein are not to be applicable for couplings other than those manufactured in accordance with this designation.

The hubless couplings described herein are composed of a stainless steel shield, clamp assembly and an elastomeric sealing sleeve conforming to the requirements of ASTM C564. This elastomeric material was selected for the sealing sleeve because the balanced combination of outstanding properties makes it resistant to abrasion, oil, grease, chemicals, sun, weather, ozone, heat and cold. This elastomeric sealing sleeve also provides a cushioning element in the coupling to avoid shock and vibration and to assure a noiseless plumbing system.

The 300 series of stainless steel was selected for the clamp and shield assemblies because it possesses high corrosion resistant characteristics, which have been demonstrated to exist in underground corrosion tests conducted by the U.S. Department of Commerce through the National Bureau of Standards.



CAST IRON SOIL PIPE INSTITUTE
1064 Delaware Avenue SE
Atlanta, Georgia 30316
Phone: 404.622.0073

1. PURPOSE AND SCOPE

1.1 Purpose. The purpose of this specification is to establish criteria for material dimensions and dimensional tolerances for one type of coupling used in hubless cast iron soil pipe and fittings for sanitary and storm drain, waste and vent piping applications in accordance with general needs of producers, distributors, and users.

1.1 Scope. This specification covers the coupling assembly identified in the following tables.

COUPLING ASSEMBLY

TABLE

Rubber Sealing Sleeve 1, 2, 2A, 3
Shield and Clamp 4, 5, 5A

Manufacturer's Item	Code			Size
	Group	Item#		
Coupling Assembly TABLES 1-6	022	0002	0	1-1/2
		0004	6	2 x 1-1/2
		0006	1	2
		0008	7	3
				3 x 2
				4 x 3
		0010	3	4
		0012	9	5
		0014	5	6
		0016	0	8
		0017	8	10
		0018	0	12
0019	0	15		

Note: When ordering by these EDP numbers, be sure to include the check (3) digit following the item number (002 0002 0). This check digit is the verification of the group and item number you select.

1.2 Several different types of hubless couplings are available for use in hubless cast iron sanitary and storm drain, waste and vent piping applications to connect hubless cast iron soil pipe and fittings by using a sleeve-type, or some other type coupling device. It is the purpose of this specification to furnish information as to the characteristics of one such sleeve-type coupling when applied to cast iron manufactured in accordance with Specification A888, latest revision, and CISPI-301, latest revision.

2 REQUIREMENTS FOR THE HUBLESS COUPLINGS REFERENCED IN THIS SPECIFICATION

2.1 DESCRIPTION. The couplings are of a sleeve-type. Each coupling shall consist of a sealing sleeve and a shield and clamp assembly which joins two spigot ends of pipe and/or fittings.

2.1.1 Each coupling is designed to permit normal expansion, contraction and deflection of the sanitary and storm drain, waste, and vent piping applications.

2.2 Sealing Sleeve. The sealing sleeve shall be tested in accordance with ASTM D3677 and be manufactured from a properly vulcanized virgin compound where the primary elastomer is polychloroprene (neoprene).

2.2.1 The sealing sleeve shall be made of a compound containing a high quality elastomer that complies with the dimensions, material specifications, chemical and physical properties as shown in Tables 1, 2, 2A and 3. All surfaces of the sealing sleeve shall be smooth except for the specified marking. The sealing sleeves shall be free from imperfections and porosity.

2.2.2 The sealing sleeve shall consist of one piece conforming to the physical requirements of Specification ASTM C564. The sealing sleeve shall be tested by the sealing sleeve manufacturer for compliance to ASTM C564 during each day of production not to exceed 24 hours for each size of sealing sleeve being produced. These tests shall be performed at the manufacturer location during the time of production. These tests shall include hardness, elongation and tensile strength, tear strength and compression set. Heat aging, water absorption, ozone resistance, and oil immersion tests shall be performed annually or when the formulation or source of supply changes, whichever occurs first.

2.2.3 When testing pipe gaskets, the prepared specimens shall be 1-in. disks cut from prepared samples .075 in. (1.905 mm) to .090-in. (2.286 mm) thick and not to exceed seven (7) plies. For hubless coupling gasket inserts a test specimen measuring .43 in. (10.922 mm) X .75 in. (19.05 mm) may be cut directly from the part provided the sample is of consistent thickness. The thickness of the sample shall be measured in accordance with Test Methods D395, section 13.1. Since all specimens from hubless pipe gaskets are curved, not flat, it is important to measure the thickness in the center of the sample with the specimen laying in a concave manner. Measure the thickness of each ply and add the measured thickness of each ply (not to exceed seven plies) to determine the original plied up thickness (to) and multiply it by .75 to determine the thickness of the spacer bar to be used (tn). Assemble the plied up specimens in the test fixture (Test Methods D395, Fig. 3) with the proper thickness spacer bars and place in oven for 22 h at 158 +/- 2°F (70 +/- 1°C). At the end of the test period take the device from the oven and remove the test specimens immediately and allow to cool in accordance with Test Methods D395, section 13.4. After the cooling period measure the final thickness at the center of the plied up test specimen placed in a concave position on the dial micrometer to determine the final thickness (ti). Calculate the compression set expressed as a percentage of the original deflection as follows:

$$CB = [(to-ti)/(to-tn)] \times 100$$

CB = compression set value test method B

to = original plied up thickness

ti = final plied up thickness

tn = thickness of spacer bar used

2.2.3.1 manufacturer sealing sleeve, n—the entity that molds the sealing sleeve covered by this standard specification.

2.3 Shield and Clamp Assembly. The shield and clamp assembly shall consist of (1) a 300 Series stainless steel corrugated shield, (2) two stainless steel bands for sizes 1 ½", 2", 3", and 4", (see Fig. 1.); four stainless steel bands for sizes 5", 6", 8" and 10", (see Fig. 2.); six stainless steel bands for sizes 12" and 15" (see Fig. 3.) and (3) a stainless steel tightening device for each band.

Each tightening device housing shall interlock with a band at the unslotted end. The bands are to be fastened to the shield by riveting or such other method that shall insure that the bands shall not become separated from the shield. The shield and clamp assembly shall comply with dimension and material specifications, as are given in Tables 4, 5, and 5A.

2.3.1 Clamp assemblies shall be tested to withstand no less than 125% of manufacturers stated installation torque or a minimum of 60 lbf-in. of applied torque, whichever is greater, without visible signs of failure. The clamp assembly shall be tested over a steel mandrel of the appropriate diameter and torqued as required. These tests shall be performed randomly on selected samples during the course of production as needed but not less than one clamp per shift per size during band production.

2.3.2 manufacturer clamp assembly and shield, n—the entity that attaches the clamp assembly to the shield for the couplings covered by this standard specification.

2.4 Marking. The sealing sleeves shall be marked with raised letters at the location shown in Table 1. This marking shall consist of pipe size, country of origin, manufacturer's identifying mark, mold number, cavity number, and ASTM C564, latest revision. Such marking shall not exceed .02" in relief.

2.4.1 The shield and clamp assembly shall be marked with indented letters at the location shown in Tables 4 and 5. All marking shall be placed on the band assemblies of the screw housing as shown in Tables 4 and 5. Marking on the band shall consist of pipe size. Marking on the screw housing shall consist of clamp manufacturer's name or registered U.S. Trademark, the words ALL STAINLESS, and country of origin.

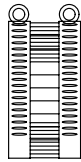

Size 1-1½"
thru 4"
TWO BANDS
Figure 1

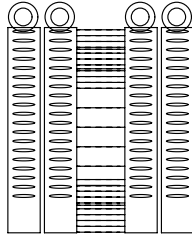

Size 5", 6", 8",
and 10"
FOUR BANDS
Figure 2

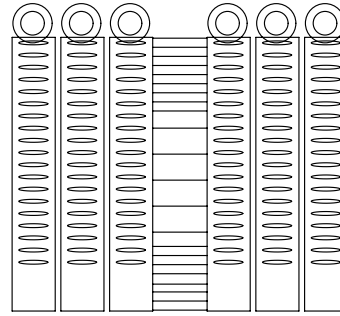

Size 12"
and 15"
SIX BANDS
Figure 3

3 COUPLINGS REQUIREMENTS AND TEST METHODS

3.1 Assemble each coupling tested according to the manufacturer's instructions between two sections of randomly selected hubless cast iron soil pipe meeting the requirements of CISPI-301 or Specification A888 and conduct the following test: deflection and shear. In addition, an unrestrained hydrostatic test shall be performed between two sections of machined steel pipe. The unrestrained hydrostatic tests shall be performed on randomly selected couplings of each size during the course of production using first article selection not to exceed 30 days. The deflection and shear tests shall be performed on randomly selected couplings of each size during production whenever a change of design occurs or not to exceed 120 days, whichever is the shorter period. **PROPER SAFETY PRECAUTIONS SHALL BE STRICTLY OBSERVED AT ALL TIMES.**

3.1.1 Deflection Test:

3.1.1.1 A test apparatus such as the one shown in Fig. 4 is suggested. Other testing apparatus that provide restraint to the assembly shall also be permitted. Close the outboard ends of the pipe with test plugs.

3.1.1.2 Fill the assembly with water, expel all air, and hydrostatically pressurize to 4.3 psi (29.6 kPa) for the duration of the test. One pipe shall be rigidly supported and while the assembly is under pressure, raise the opposite end of the other pipe 1/2 in. (12.7 mm) per linear foot of pipe. Maintain the pressure for 5 minutes. Any leakage shall mean failure.

3.1.2 Shear Test:

3.1.2.1 Support two joined lengths of randomly selected hubless cast iron soil pipe on blocks, a minimum of 1½ in. (38.1 mm) high, at three locations. One length shall be a minimum of 24 in. (609.6 mm) in length, supported on blocks, one near the uncoupled end, and the other immediately adjacent to the couplings. Firmly restrain this length in position as shown in Fig. 5. The other coupled length shall be a minimum of 5 ft (1.52 m) in length and supported by a single block 6 in. (152.4 mm) from the end of the pipe.

3.1.2.2 Fill the assembly with water and expel all air. Apply a load of 50 lb/in. of nominal diameter at a point 6 in. (152.4 mm) from the edge of the coupling upon a 12 in. (304.8 mm) length of (3 by 3) angle iron or load distribution pad located on the top of the pipe immediately adjacent to the coupling of the pipe having one support only. Under this loading there shall be no visible leakage or displacement of more than 3/8 in. (9.53 mm) from true alignment adjacent to the coupling, when an internal pressure equivalent to a 10 ft (3.05 m) head of water 4.3 psi (29.6 kPa) is applied. Maintain the load and internal pressure for 15 minutes.

3.1.3 Unrestrained Hydrostatic Test:

3.1.3.1 Assemble each coupling tested according to the manufacturer's instruction between two sections of machined steel pipe and conduct the thrust test.

3.1.3.2 The assembly shall consist of a maximum outside diameter pipe connected to a minimum outside diameter pipe with diameters as referenced in Table 6 and lengths as shown in Fig. 6. Machine the plain ends of the pipe to be used for the thrust test to the correct diameters. Plain ends shall have 0.015 in. (0.38 mm) deep grooves machined circumferentially around them at 1/8in. (3.18 mm) intervals down the pipe section for a distance equal to that covered by the elastomeric sealing sleeve of the coupling being tested. The tool used to machine the grooves shall have a 60° inclined angle and cut into the pipe from a perpendicular position. The surface between the grooves shall be a lathe turned surface of 125 RMS.

3.1.3.3 The plain ends of the pipe for the thrust test shall be uncoated and cleaned with acetone and thoroughly dried before each assembly.

3.1.4 Test Method:

3.1.4.1 Support the pipe assemblies in a manner that does not restrain joint movement as shown in Fig. 6.

3.1.4.2 Fill the pipe assembly (as required in 3.1.3) with water, expelling all air. Increase the hydrostatic pressure at a rate of 1 psi (6.9 kPa) every 30 s until the specified test pressure is reached. The specified test pressure shall be 20 psi (137.9 kPa) for 1 1/2 in. (38.1 mm) through 5 in. (127 mm), 18 psi (124.1 kPa) for 6 in. (152.4 mm), 10 psi (68.9 kPa) for 8 in. (203.2 mm), and 6 psi (41.4 kPa) for 10 in. (254 mm) pipe, 12 in. (305 mm), and 15 in. (380 mm). When the specified test pressure is reached, hold it for 5 minutes. Any leakage or axial joint movement of more than 0.150 in. (3.81 mm) shall mean failure.

4 CERTIFICATION

4.1 Upon request the purchaser, design professional, or the administrative authority having jurisdiction where the products are being installed, shall be furnished certification documents by the manufacturer, stating samples representing each lot have been tested and inspected by the manufacturer for quality as indicated in this specification and the requirements have been met. If requested by the purchaser, design professional, or the administrative authority having jurisdiction where the products are being installed, self-certification shall be accompanied by manufacturer quality control test reports as prepared in accordance with Sections 2 & 3 of this specification. Self-certification shall include the legal name and address of each manufacturer.

4.2 Third Party certifiers or inspectors shall utilize the procedures detailed in Annex A when conducting inspections at the manufacturing locations.

TABLE 1. RUBBER SEALING SLEEVE
(Dimensions in inches)

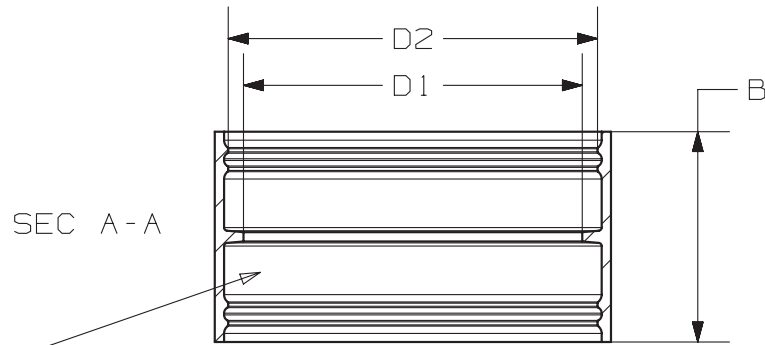

MARKINGS SHALL BE BETWEEN SEALING RINGS AND CENTER STOP.
MARKINGS SHALL BE PERMITTED ON BOTH SIDES OF CENTER STOP.

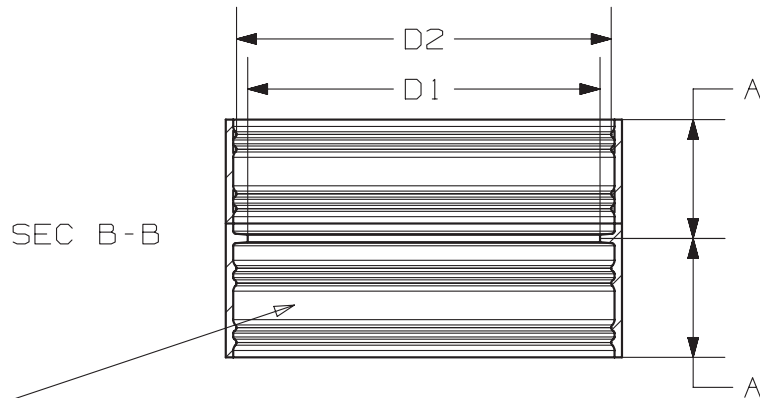
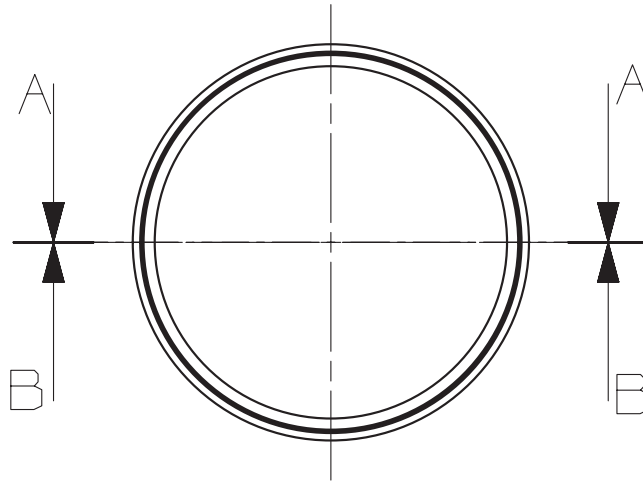

MARKINGS SHALL BE BETWEEN SEALING RINGS AND CENTER STOP.
MARKINGS SHALL BE PERMITTED ON BOTH SIDES OF CENTER STOP.

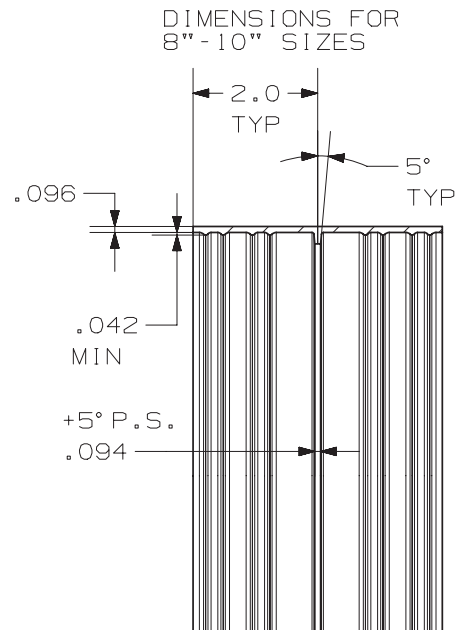
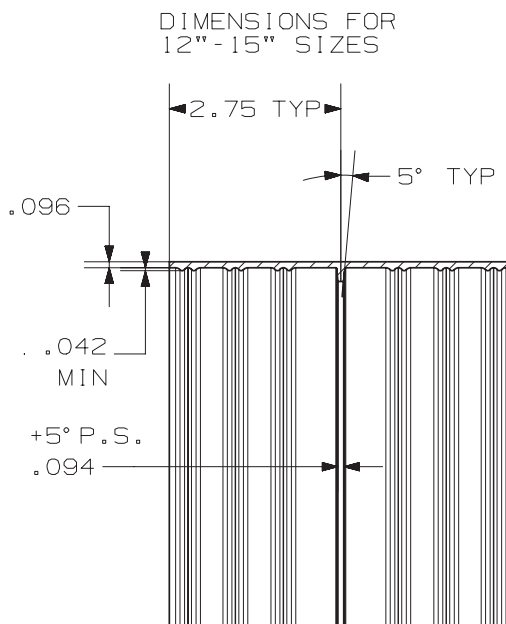
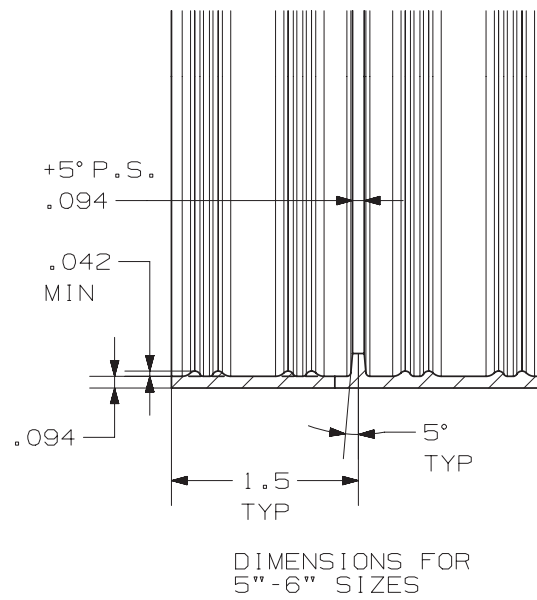
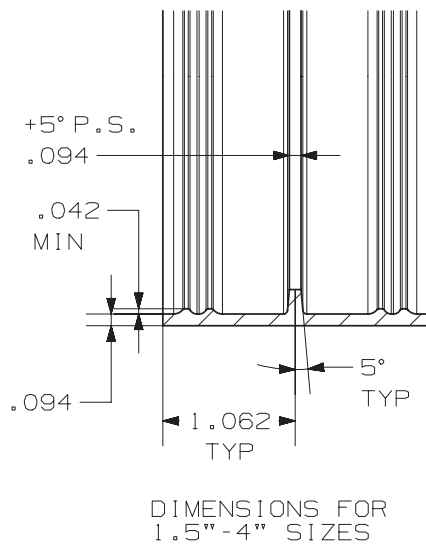

Note – Dimensions found in these drawings are for informational purposes only. the dimensions A and B found in the table are mandatory. Dimensions D1 and D2 found in the table are reference for mold design. Tolerances are found in Fig. 2. The center stop width is (3/32) .094 plus the 5° draft angle. Sealing ring shape and dimensions are to manufacturer’s design.

DIMENSIONS IN INCHES										
	1½"	2"	3"	4"	5"	6"	8"	10"	12"	15"
B	2.125	2.125	2.125	2.125	3.000	3.000	4.000	4.000	5.500	5.500

Dimensional Tolerances to be RMA Class 3 (See Table 2A)

TABLE 2: REDUCING RUBBER SEALING SLEEVE
(Dimensions in inches)

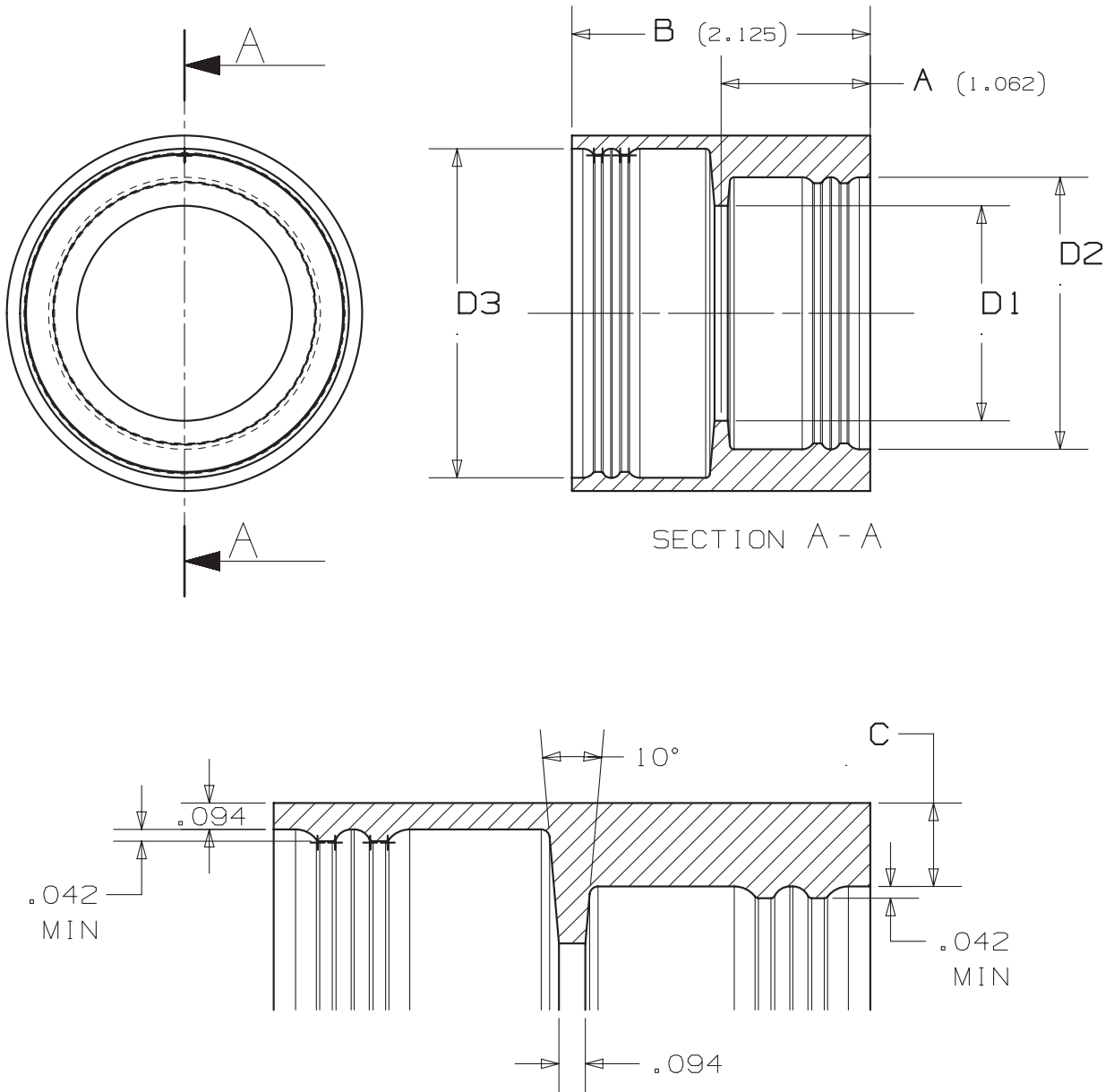

*Note – C dimension is a reference dimension only

DIMENSIONS FOR REDUCING SEALING SLEEVES

DIMENSIONS IN INCHES			
	2" x 1-1/2"	3" x 2"	4" x 3"
A	1.062	1.062	1.062
B	2.125	2.125	2.125
C	0.297	0.594	0.625
D1	1.531	1.968	2.968
D2	1.937	2.343	3.343
D3	2.343	3.343	4.406

Dimensional Tolerances to be RMA Class 3 (See Table 2A)

TABLE 2A. DIMENSIONAL TOLERANCES FOR RUBBER
Standard Dimensional Tolerances RMA CLASS 3

Size (Inches)	Closure (Plus or Minus)
0 – 0.499	0.015
0.500 – 0.999	0.018
1.000 – 1.999	0.020
2.000 – 2.999	0.025
3.000 – 3.999	0.030
4.000 – 4.999	0.035
5.000 – 7.999	0.050

8.000 and over – multiplied by 0.0050. These are commercial tolerances.
All diametral dimensions shall have a tolerance of +/- 1 percent.

TABLE 3. RUBBER SEALING SLEEVE PHYSICAL REQUIREMENTS

- Material:** The sealing sleeve shall be made from an elastomeric compound that meets the requirements of ASTM C564. The sealing sleeve shall be tested in accordance with ASTM D3677 and be manufactured from a properly vulcanized virgin compound where the primary elastomer is polychloroprene (neoprene).
- Physical Tests:** The test specimens shall be obtained from finished sealing sleeves and tested pursuant to the methods described in the following table.

TESTS

Test	Physical Tests Min or Max Requirements	ASTM Method
Tensile Strength	1500 psi min.	D412
Elongation	250 min.	D412
Durometer (Shore A)	70 ± 5 @ 76° F ± 5° F	D2240
Accelerated Aging	15% max. tensile and 20% max. elongation deterioration, 10 points max. increase in hardness, all determinations after oven aging for 96 hours at 158 ° F.	D573
Compression Set	25% max after 22 hours at 158° F.	D395 Method B
Oil Immersion	80% max. volume change after immersion in ASTM oil IMR903 for 70 hours at 212° F.	D471
Ozone Cracking	No visible cracking at 2 times magnification of the sealing sleeve after 100 hours exposure in 1.0 ppm ozone concentration at 100° F. Testing and inspection to be on sealing sleeve which is loop mounted to give approximately 20% elongation of outer surface.	D1149
Tear Resistance	Die C; 150 lbs. Min. per inch of thickness	D624
Water Absorption	20% max. by weight after 7 days at 158° F.	D471

TABLE 4. SHIELD AND CLAMP ASSEMBLY
(Dimensions in inches)

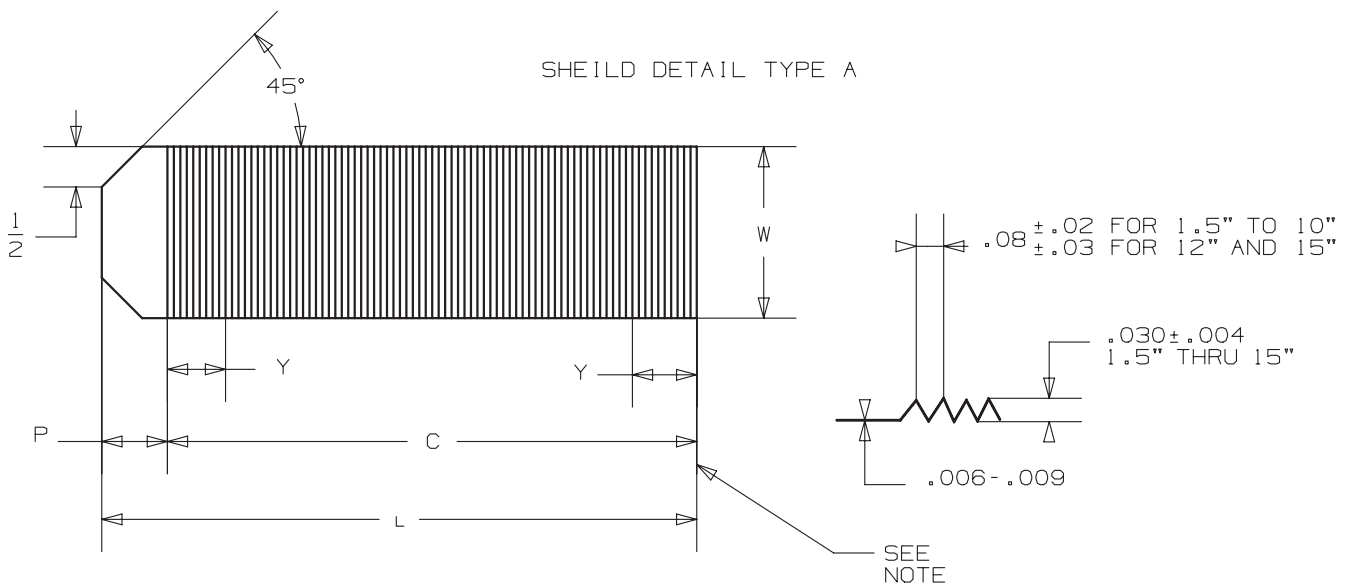
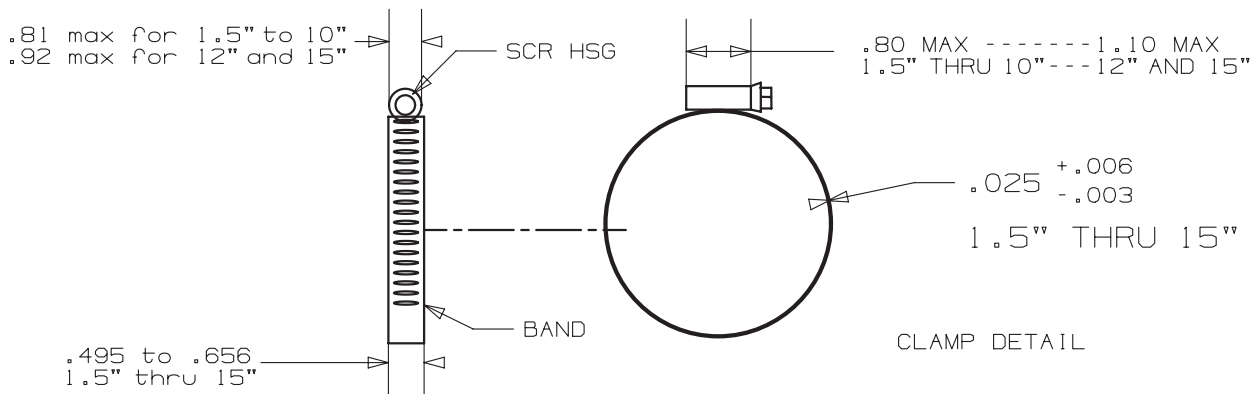
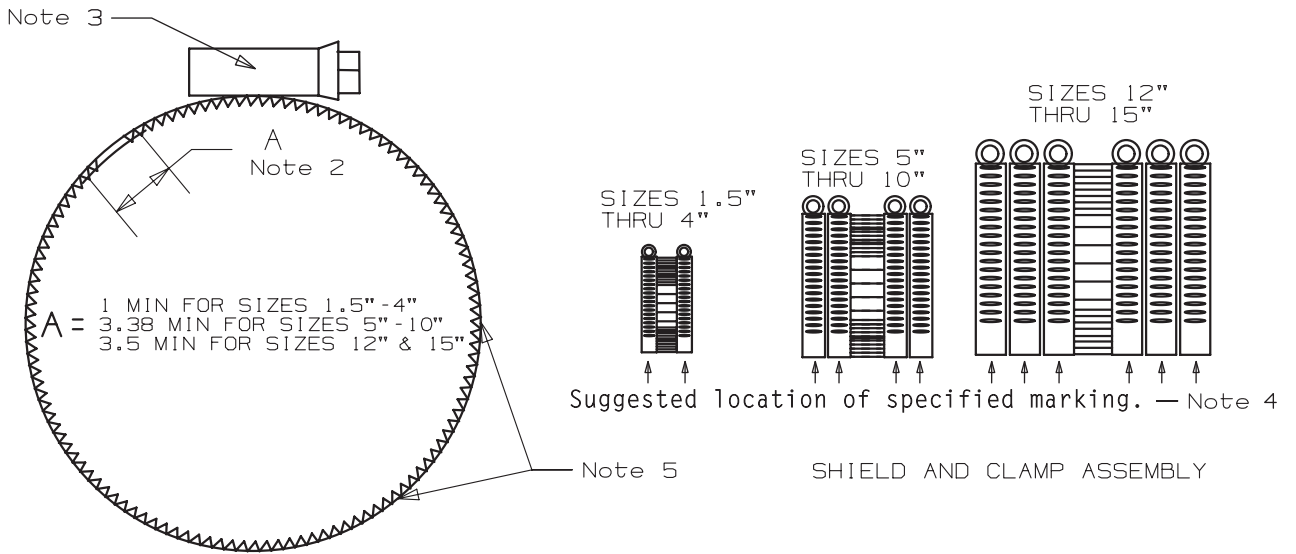

Note: A single corrugation pattern is shown in drawing other corrugations unique to individual manufacturers are acceptable. The “P” dimension is allowed on either end of corrugated section. A “P” dimension is required on shield designs that have a single corrugated pattern. It shall be permitted for the “P” dimension to not apply to all coupling designs. Measure the corrugated material thickness and formed thickness with calipers or disc micrometer. Three random measurements of shield thickness and corrugated height shall be taken and the median used as the value.

Pipe Size	Dimensions in Inches					
	P	*C	L min	W	Min.	X ⁷ Max.
1 ½”	0.813 ± 0.25	6.688	7.37	2.125 +/- 0.010	1.50	2.50
2”	0.813 ± 0.25	8.188	8.87	2.125 +/- 0.010	2.00	3.00
3”	0.813 ± 0.25	11.438	12.12	2.125 +/- 0.010	3.00	4.00
4”	0.813 ± 0.25	14.813	15.49	2.125 +/- 0.010	4.00	5.00
5”	2.375 ± 0.50	17.563	19.69	3.000 +/- 0.015	5.30	6.20
6”	2.375 ± 0.50	20.250	22.38	3.000 +/- 0.015	6.30	7.20
8”	3.000 ± 0.50	26.000	28.75	4.000 +/- 0.015	8.30	9.20
10”	3.000 ± 0.50	33.250	36.00	4.000 +/- 0.015	10.45	11.35
12”	3.500 ± 0.50	39.100	42.30	5.500 +/- 0.015	12.53	13.27
15”	3.500 ± 0.50	49.200	52.40	5.500 +/- 0.015	15.75	16.49

*Note – C Dimension is a reference dimension only.

MATERIAL SPECIFICATIONS

Band – Type 301 AISI Stainless Steel – Minimum Tensile 140,000 PSI for 1 ½” to 15”;
 Type 304 AISI Stainless Steel shall be permitted;
 Type 304 AISI Stainless Steel – Minimum Tensile 140,000 PSI.

Screw Housing – Type 301 AISI Stainless Steel for 1 ½” to 15”;
 Type 304 AISI Stainless Steel shall be permitted.

Screw - Type 305 AISI and or Type 304L AISI Annealed Stainless Steel – 5/16” Hex Head/Shoulder for 1 ½” – 10”; 3/8” Hex Head/Shoulder for 12” and 15” is required for couplings which require installed torque greater than 60 inch pounds. When other than 3/8” hex head screw is used on 12” and 15” couplings, the coupling shall be labeled with the required installation torque.

Shield - Type 301 AISI and or Type 304 AISI Stainless Steel – Bright Annealed Only (Annealed & Pickled Not Acceptable)
 Hardness – Rockwell B-100 (Vickers 240) per ASTM A240/A240M Max. – (Max. Burr Height Not to Exceed 25% of Thickness)

Eyelets/Rivets - Type 300 Series AISI Stainless Steel

Notes

- 1 Construction for sizes 1 ½” thru 10” shields have corrugations tapering in height from 0.000” to 0.030” at dimension “Y”. Y equals maximum of 1 inch. (Type A Only)
- 2 Position clamps on shield as shown from inside end of clamp. Shield overlap to be as shown or reversed on 5”, 6”, 8”, 10”, 12” and 15” only.
- 3 Location of Specified marking – Manufacturer’s name, all stainless, country of origin, trade name or mark. See Table 5 for details.
- 4 Location of specified marking – Size See Table 5 for details.
- 5 Securely fasten each clamp to shield, two places for sized 1 ½” to 4”, three places for sizes 5”, 6”, 8”, 10”, 12”, and 15”.
- 6 Details of detent on 5”, 6”, 8”, and 10” bands are shown in Table 5A (optional for 12” and 15”).
- 7 Max “X” is that dimension to which the clamp must open and still maintain positive engagement of the screw in the slots of the clamping band. Min. “X” is that dimension to which the clamping band must close and still maintain positive engagement of the screw in the slots of the clamping band.

TABLE 5. DETAILS OF SPECIFIED MARKING

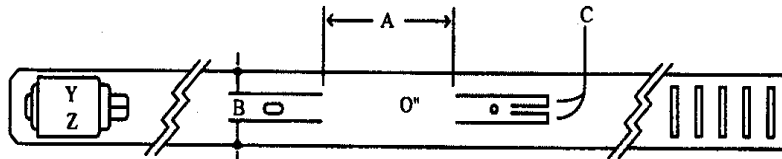

Lettering shall be located so that it will not be covered by emerging band.

All Sizes

A = 1.250" Nominal .750" Minimum

B = .250" Nominal All Sizes

C = .094" Nominal All Sizes

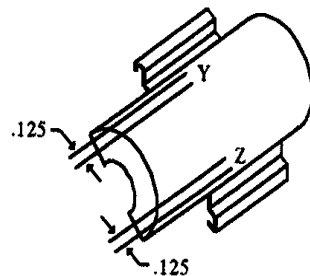

Y - Clamp Manufacturer's Name or U. S. Registered Trade Mark
Z - All Stainless and Country of Origin

Housing Detail
Markings Y, & Z ± .063

TABLE 5A DETAILS OF DETENT ON 5, 6, 8 & 10 INCH BANDS
(OPTIONAL ON 12 & 15 INCH)

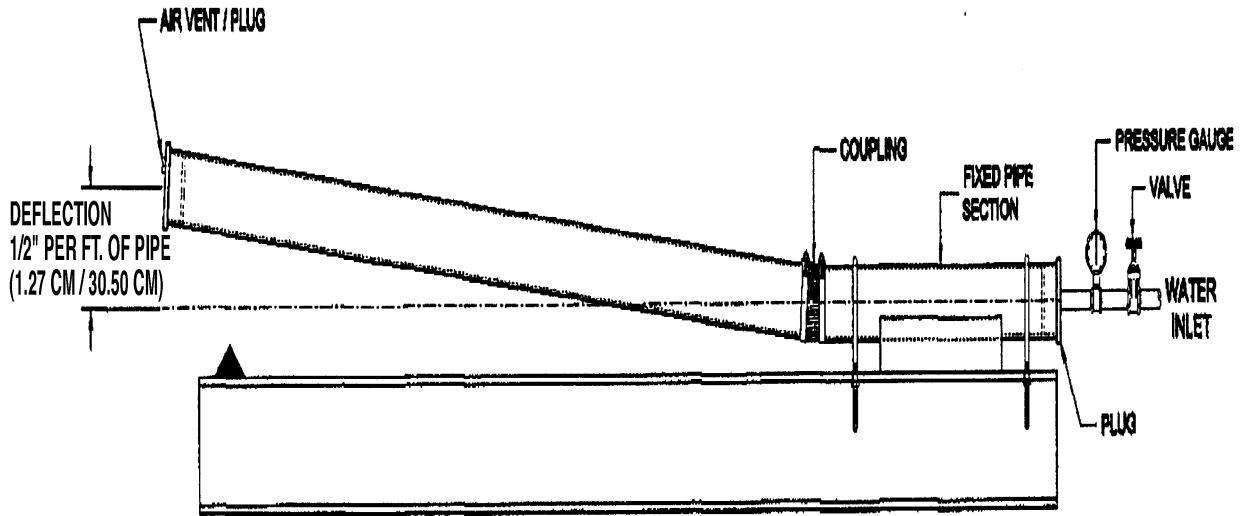
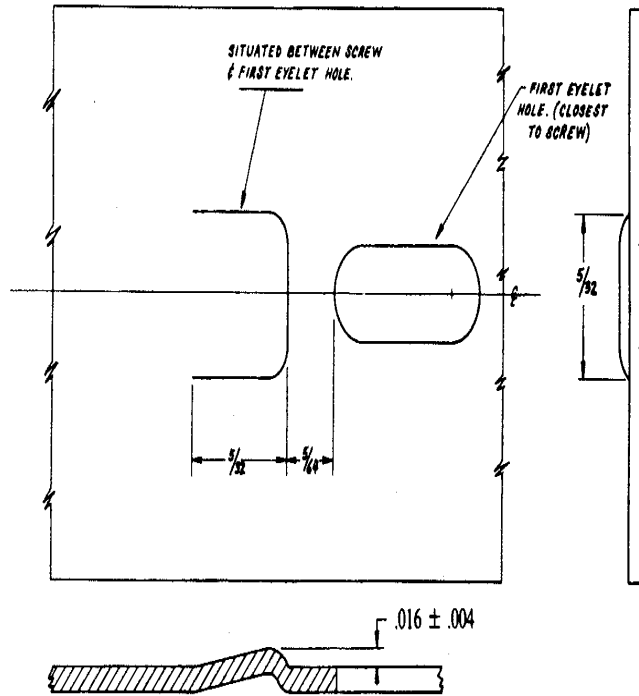

FIG. 4 Deflection Test

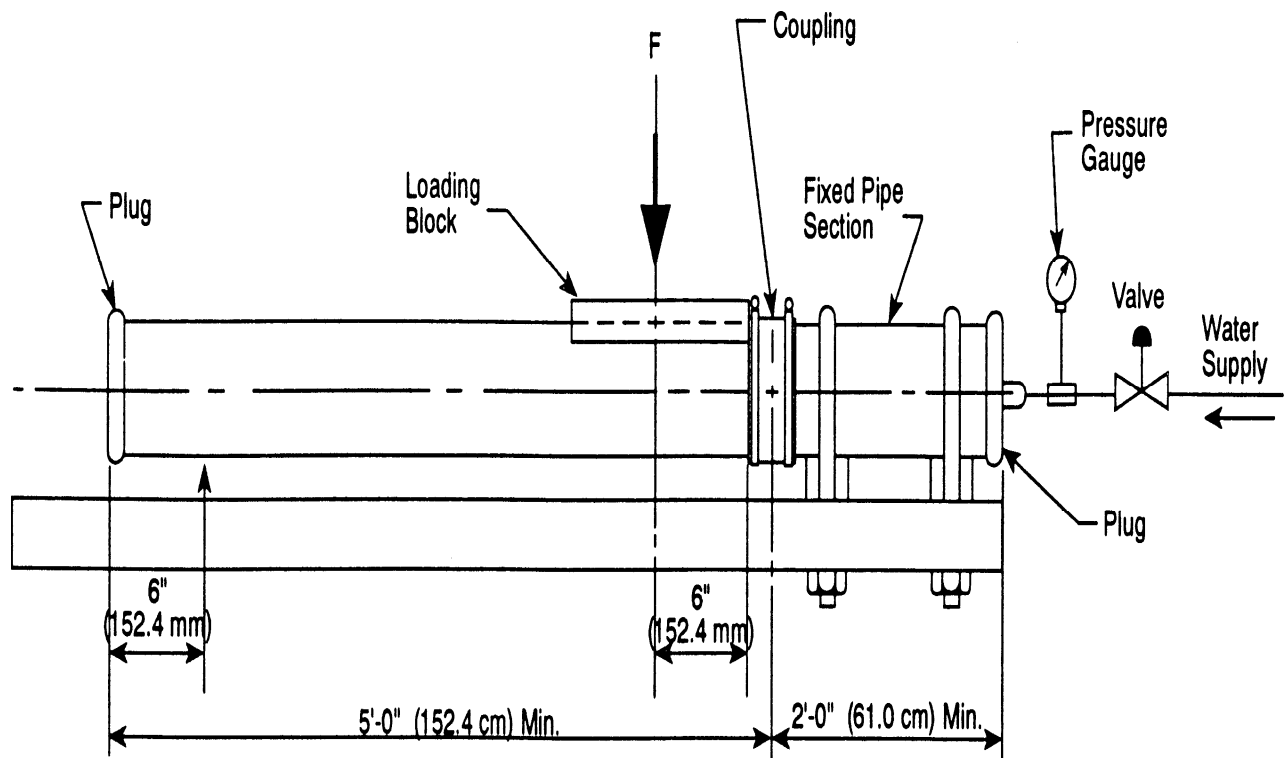

FIG. 5 Shear Test

TABLE 6 Dimensions and Tolerances for Hubless Pipe and Fittings

Size, in. (mm)	Outside Diameter, in. (mm)
1 1/2 (38)	1.90 ± 0.06 (48.26 ± 1.52)
2 (51)	2.35 ± 0.09 (59.69 ± 2.29)
3 (76.2)	3.35 ± 0.09 (85.09 ± 2.29)
4 (102)	4.38 + 0.09/-0.05 (111.25 + 2.29/-1.27)
5 (127)	5.30 + 0.09/-0.05 (134.62 + 2.29/-1.27)
6 (152)	6.30 + 0.09/-0.05 (160.02 + 2.29/-1.27)
8 (203)	8.38 ± 0.09 (212.85 ± 2.29)
10 (254)	10.56 ± 0.09 (268.22 ± 2.29)
12 (305)	12.50 ± 0.13 (317.5 ± 3.30)
15 (380)	15.83 ± 0.13 (402.8 ± 3.30)

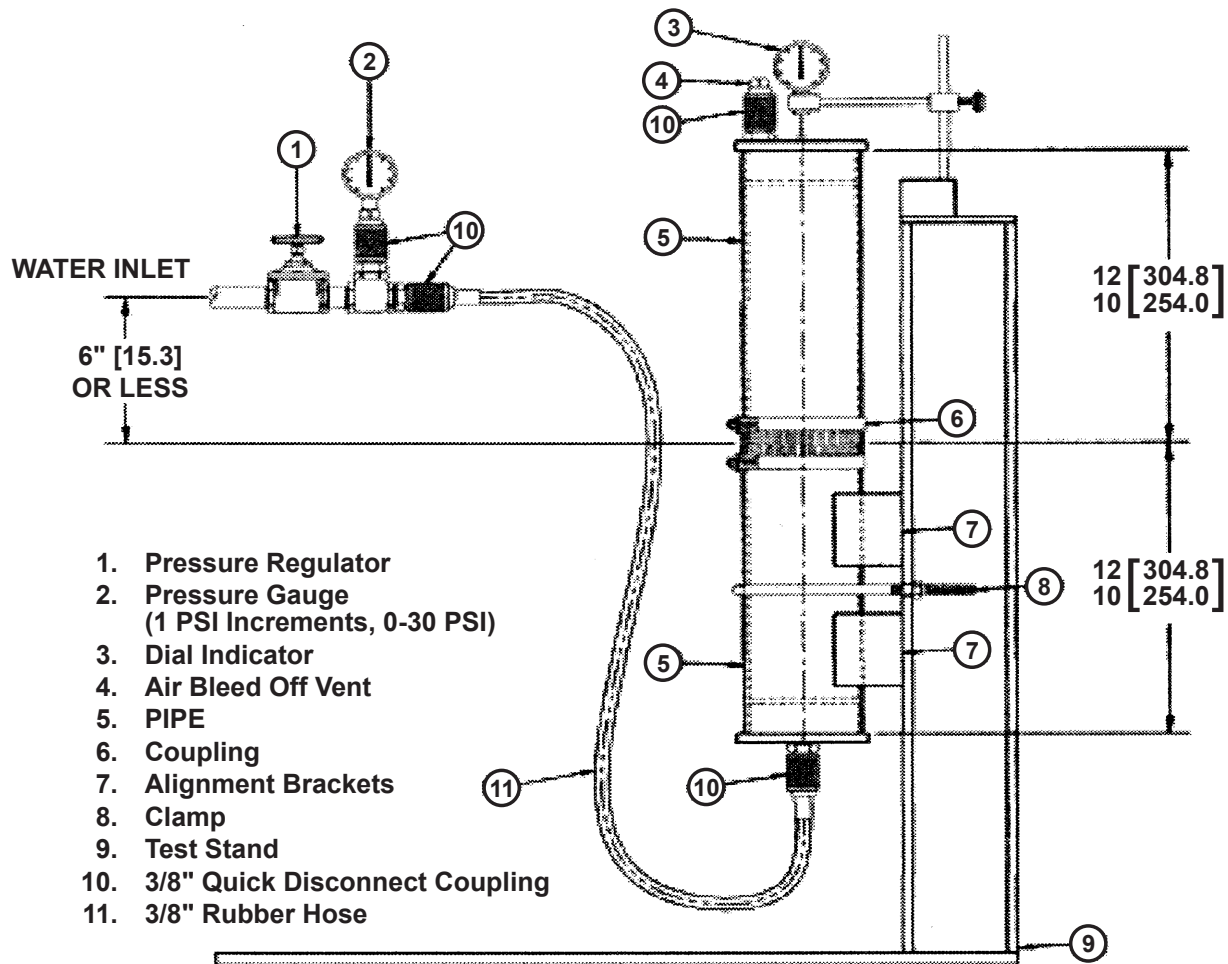

FIG. 6 Unrestrained Hydrostatic Test

Annex A
 (Mandatory Information)

The following supplementary requirements shall be applied when the manufacturer or seller of the products covered by this specification utilizes third party certification agencies as part of their certifications as detailed in Section 4, Certification of this specification.

A1. Third Party certification audit or inspection

A1.1 Third Party certifiers or inspectors conducting regular inspections at the manufacturer's production facility shall include but not be limited to the following procedures during each audit or inspection

A1.1.1 A review of the manufacturer's records to verify compliance with Sections 2 and 3 of this standard. Copies of the manufacturer's quality control test reports shall be added to the third party certifier's audit or inspection reports.

A1.1.2 Random inspection of the manufacturer's finished goods inventory shall be conducted during each audit or inspection. These audits or inspections shall include a dimensional and marking inspection of not less than 10 randomly selected couplings of different sizes and types. Each sealing sleeve used as part of a coupling shall be subject to the requirements of the appropriate coupling standard.

APPENDIX

The following non-mandatory appendix includes installation suggestions for the proper installation of the hubless cast iron soil pipe and fittings joined by the couplings included in this CISPI 310 designation. These suggested instructions shall not be considered a mandatory part of this designation.

NON-MANDATORY APPENDIX

Suggested Installation Instructions

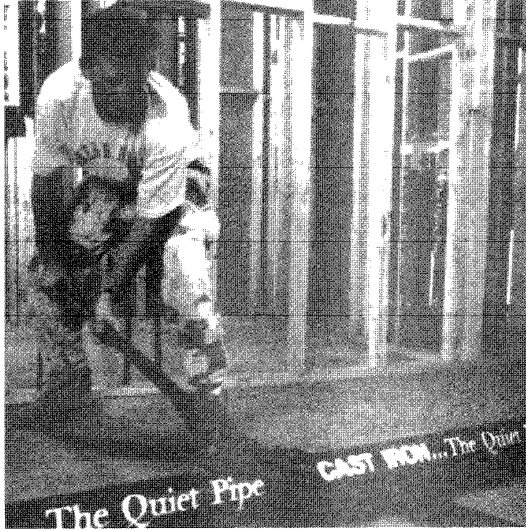

**ASSEMBLING HUBLESS CAST IRON SOIL PIPE IS LITERALLY A SNAP.
ONLY TWO TOOLS ARE REQUIRED, A PIPE CUTTER AND TORQUE WRENCH.**



INSTALLATION PROCEDURES FOR HUBLESS CAST IRON SOIL PIPE AND FITTINGS FOR SANITARY AND STORM DRAIN, WASTE AND VENT PIPING APPLICATIONS

1. Introduction

1.1 Several different types of hubless couplings are available for use in hubless cast iron sanitary and storm drain, waste, and vent piping applications to connect hubless cast iron soil pipe and fittings by using a sleeve-type, or some other type coupling device. It is the purpose of this portion of designation CISPI 310-12 to furnish procedures as to the installation of couplings, which are manufactured in accordance with CISPI Designation 310-12 when applied to cast iron soil pipe and fittings manufactured in accordance with CISPI Standard 301, latest revisions.

It must be noted that these installation procedures are not intended to be applicable for couplings not made in accordance with CISPI 310-12.

THE INSTALLATION PROCEDURES STATED BELOW ARE ILLUSTRATIVE ONLY AND ARE NOT A MANDATORY PORTION OF CISPI DESIGNATION 310-12.

2. Purposes

2.1 These installation procedures provide guidelines for installation, use and inspection of hubless cast iron soil pipe and fittings for sanitary and storm drain, waste, and vent piping applications when the coupling device described in Designation 310-12 is used.

2.2 All construction projects involve many variables, hence it is not possible to state in advance every installation consideration which may apply in the field. In the end, the final and controlling judgment decisions concerning installation questions that arise must be made in the design and “on the job” taking into account prevailing circumstances or conditions. The Institute cannot assume such responsibilities. These procedures are not a substitute for such informed judgments and for manufacturer-provided installation instructions but it is hoped they will be helpful.

2.3 Complete stability of all components of hubless cast iron soil pipe and fittings for sanitary and storm drain, waste, and vent piping applications should be given prime consideration.

3. Methods of Cutting Cast Iron Soil Pipe

There are several methods of successfully cutting cast iron soil pipe. These methods may be placed into two basic categories; those that require external power for their operation and those methods that require only hand operation. Methods that require external power are usually used for prefabrication work or high volume cutting operations. Examples of this type of equipment would be: (1) the abrasive saw (chop SAW), (2) power hack saw, and (3) an electrically actuated hydraulic snap cutter. Before using electrical equipment of this nature, the manufacturer’s operating instructions should be carefully reviewed for safe use of the equipment.

There are two hand operated cutting tools that are used in the industry today: (1) the standard steel pipe cutter using cutting wheels specifically designed to cut cast iron soil pipe, and (2) the snap cutter. The snap cutter accounts for the majority of all cuts made on cast iron soil pipe in the field.

There are several types of snap cutters available, the following procedure has been found to produce consistently good cuts:

- 1) After marking the pipe length to be cut, position the chain cutter squarely around the pipe to ensure a straight cut. The maximum number of wheels possible should be in contact with the pipe.
- 2) Score the pipe by applying pressure on the handles to make the cutter wheels indent the pipe.
- 3) Rotate the pipe a few degrees and then apply quick final pressure to complete the cut. If a piece of pipe is unusually tough, score the pipe several times before making your final cut. Scoring the pipe before the actual cut is the key to a clean straight cut.

Cast iron soil pipe may also be cut with a hammer and a cold chisel. This method of cutting is very time consuming and should only be used if snap cutters are not available. Again, protective equipment, such as safety goggles, should be used. The procedure for cutting soil pipe with a hammer and chisel are as follows:

- 1) Measure the length to be cut and mark the cut line completely around the circumference of the pipe.
- 2) Place the mark to be cut on a 2 by 4 so the edge of the 2 by 4 is directly under the mark.
- 3) By striking the chisel with the hammer, cut a groove following your mark all the way around the circumference of the pipe.
- 4) Continue cutting as outlined above in (3) until the pipe is cut. This procedure may take several revolutions of the pipe before it is cut.

Installers should be aware of safety considerations, including the need to use protective equipment, such as safety goggles, when cutting cast iron soil pipe.

4 Definitions

- 4.1 Joint**—A place where two ends of pipe or fittings are connected.
- 4.2 Coupling**—A mechanical device by which the ends of pipe or fittings are connected.
- 4.3 Hanger**—A device by which or to which something is hung or hangs.
- 4.4 Support**—To hold up or to serve as a foundation or prop.
- 4.5 Restrain**—To limit, restrict or keep under control.
- 4.6 Restraint**—A device that restricts movement.
- 4.7 Seismic**—Shock, earthquake, to shake.
- 4.8 Torque**—A force that produces or tends to produce rotation or torsion: A turning or twisting force.
- 4.9 Alternately**— A change from one to another repeatedly.

5 Clamp and Sealing Sleeve Installation

Hubless cast iron soil pipe is joined by using the hubless coupling. Several different types of hubless couplings are available. The following will outline the installation procedures of hubless couplings that meet the requirements of CISPI 310-12. It must be noted that these installation procedures

are not intended to be applicable for couplings other than those manufactured in accordance with CISPI 310-12. Installation procedures from the manufacturer shall be followed for best performance. These couplings are manufactured using a stainless steel shield and clamp assembly and an elastomeric sealing sleeve conforming to the requirements of Specification C564. The following steps should be taken to ensure a proper joint.

- 1) Place the sealing sleeve on the end of one pipe or fitting and the stainless steel clamp and shield assembly on the end of the other pipe or fitting.
- 2) Firmly seat the pipe or fitting ends against the integrally molded center stop inside the elastomeric sealing sleeve.
- 3) Slide the stainless steel shield and clamp assembly into position centered over the sealing sleeve and tighten the bands. The bands should always be tightened using a properly calibrated torque wrench set at 60 lbf-in. or the specific torque required by the manufacturer of couplings, which require a higher torque. For larger diameter couplings that have four bands, the inner bands should be tightened first and then the outer bands tightened. In all cases, when tightening bands they should be tightened alternately to ensure that the coupling shield is drawn up uniformly.

(A) TYPICAL HUBLESS COUPLING

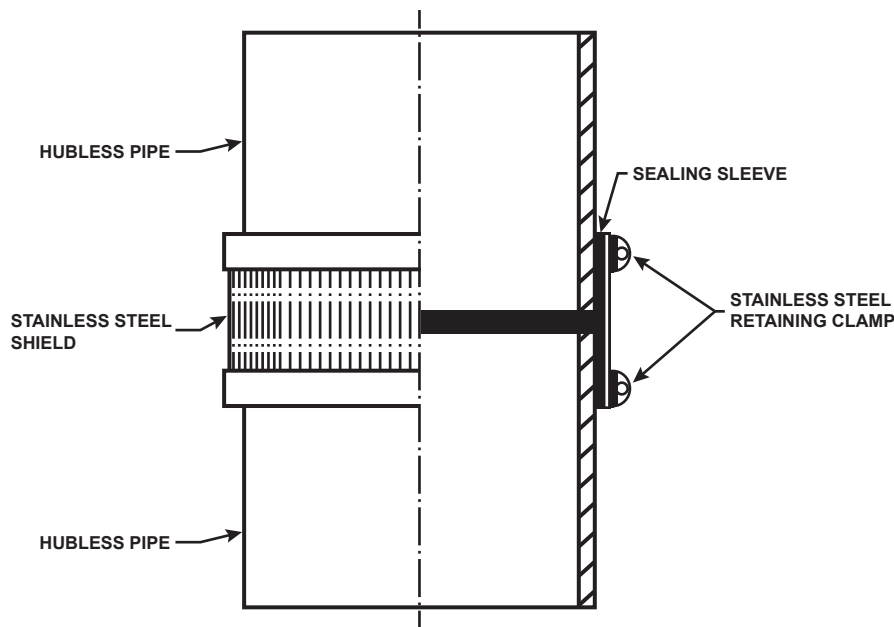

6. SUGGESTED INSTALLATION INSTRUCTIONS

UNDERGROUND INSTALLATION PROCEDURES

The physical properties of cast iron soil pipe make it a good choice for DWV (Drain, Waste and Vent) material for underground installation. The two keys for proper underground installation are trench preparation and backfilling.

The trench should be wide enough to assemble the joints. Total load on the pipe includes both earth load and the truck load. For additional information refer to CISPI's "Trenching Recommendations for Cast Iron Soil Pipe" brochure or the CISPI handbook. **Safety procedures in trenching should be observed, including provisions to avoid collapse of the trench wall.**

The trench bottom should be stable enough to support the complete barrel of the pipe. If possible the barrel should rest on even and undisturbed soil. In certain conditions, that is, rocky, it becomes necessary to excavate deeper than needed, place and tamp back fill material to provide an appropriate bed. Holes should be provided at each joint for the hub or couplings to allow for continuous support of the barrel along the trench bottom. If the ditch must be excavated deeper than the depth of the drainage pipe, place and tamp backfill material to provide uniform support for the pipe barrel.

Many times in the installation of underground soil pipe it is necessary to change the direction of the line. Cast iron soil pipe will allow this through deflection in the joints. Installation should initially be completed in a straight line and then deflected to the appropriate amount. Maximum deflections should not exceed 1/2 in. per foot of pipe. This would allow 5 in. of deflection for a 10-ft piece of soil pipe. For changes in direction greater than these deflections an appropriate fitting should be used.

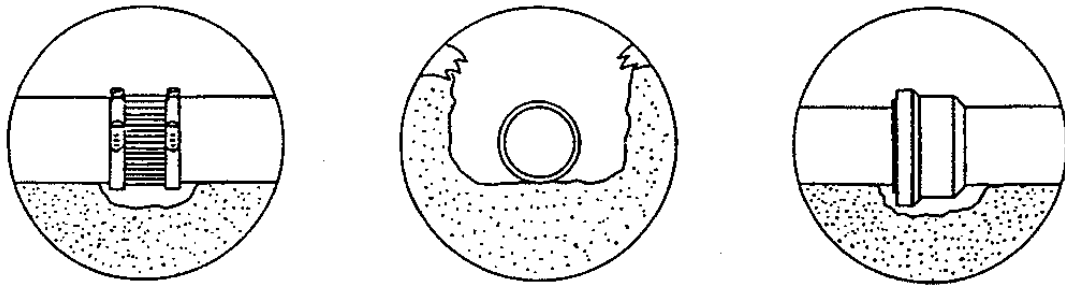

TYPE 1 TRENCH CONDITION

No Pipe Bedding, Hard Trench Bottom, Continuous Line Support with Hub or Coupling Holes

¹ The use of adhesive lubricants is permissible as recommended by the manufacturer. When adhesive lubricants are used wait 24 hours before testing. The use of adhesive lubricant does not take the place of proper joint restraint.

Once installation (for joining methods refer to Part 5) is completed, the underground section is ready for test. Because this portion of the system is usually the largest diameter pipe it may be necessary to restrain the system or joints from movement prior to testing. This may be done by partially backfilling and leaving the joints exposed for inspection, or rodding or bracing, or both.

After testing is completed, the trench can be properly backfilled. When backfilling, care should be taken to protect the pipe from large rocks, stones, or frozen fill material etc., that could damage the pipe. Cast iron soil pipe laid on a solid trench bottom requires no tedious placement of selected backfill materials.

Installers should always consider local conditions, codes, manufacturer instructions, and architect/engineer instructions in any installation.

ABOVEGROUND INSTALLATION PROCEDURES

With attention to a few basic rules the installation of cast iron soil pipe and fittings is easily accomplished.

- 1) Cast iron soil pipe installed in the horizontal position shall be supported at every coupling. The hanger shall be placed within 18 in. of the coupling. Joints used for connecting cast iron soil pipe possess sufficient shear strength to require one hanger per joint. For 12 in. and 15 in. hubless pipe, hangers shall be placed on both sides of the coupling when installing full 10-ft lengths.
- 2) Installations requiring multiple joints within a four foot developed length shall be supported at every other or alternating couplings.

Vertical components shall be secured at each stack base and at sufficiently close intervals to keep the system in alignment and to adequately support the pipe and its contents. Riser clamps, sometimes called floor or friction clamps are required for vertical piping in multi-story structures in order for each floor not to exceed 15 ft.

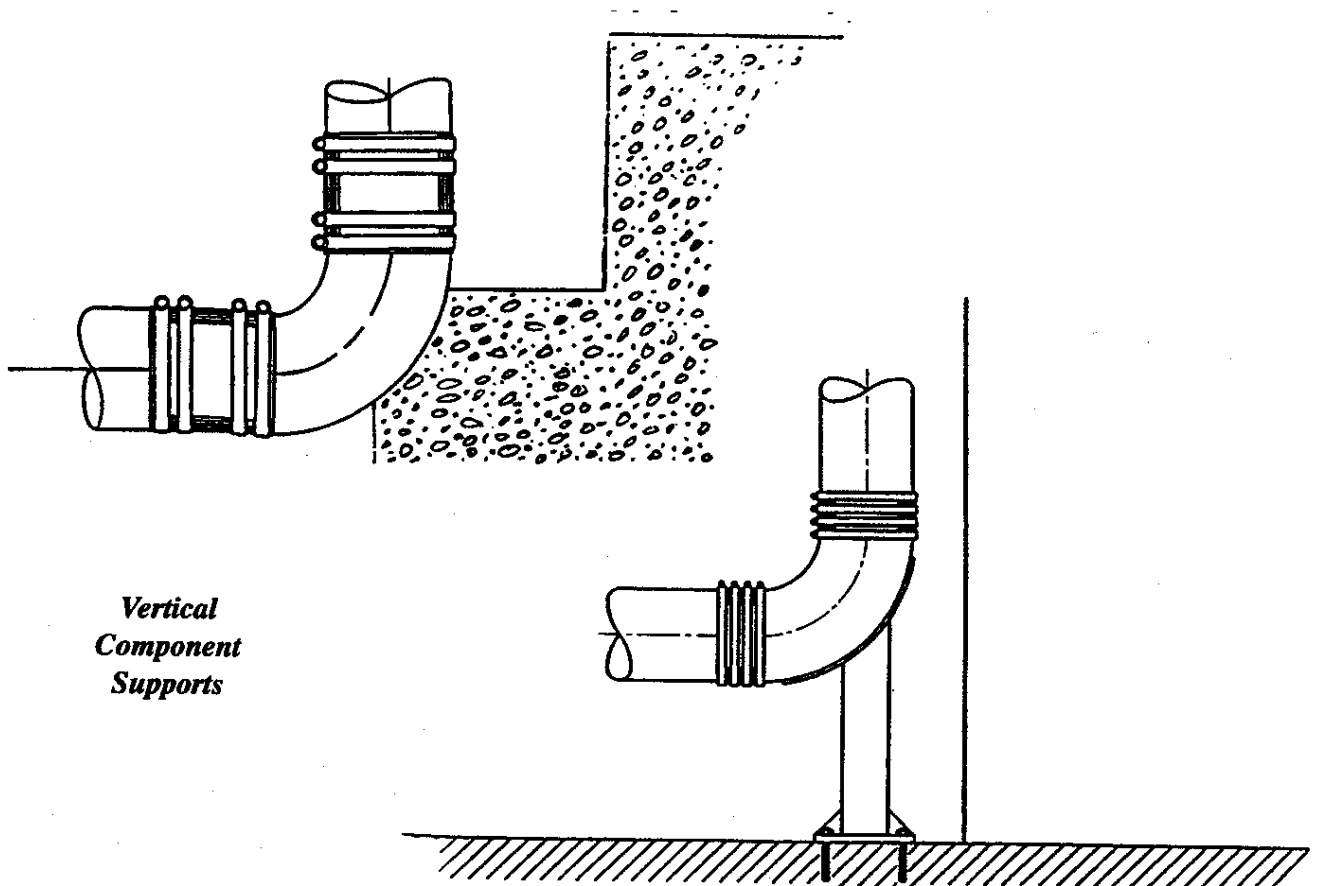

Large Diameter Fittings

Horizontal pipe and fittings five (5) in. and larger shall be suitably restrained to prevent horizontal movement. This shall be done at every branch opening or change of direction by the use of braces, blocks, rodding or other suitable method, to prevent movement.

Closet bends, traps, trap-arms and similar branches must be secured against movement in any direction. Closet bends installed above ground shall be stabilized by firmly strapping and blocking. Where vertical closet stubs are used they must be stabilized against horizontal or vertical movements.

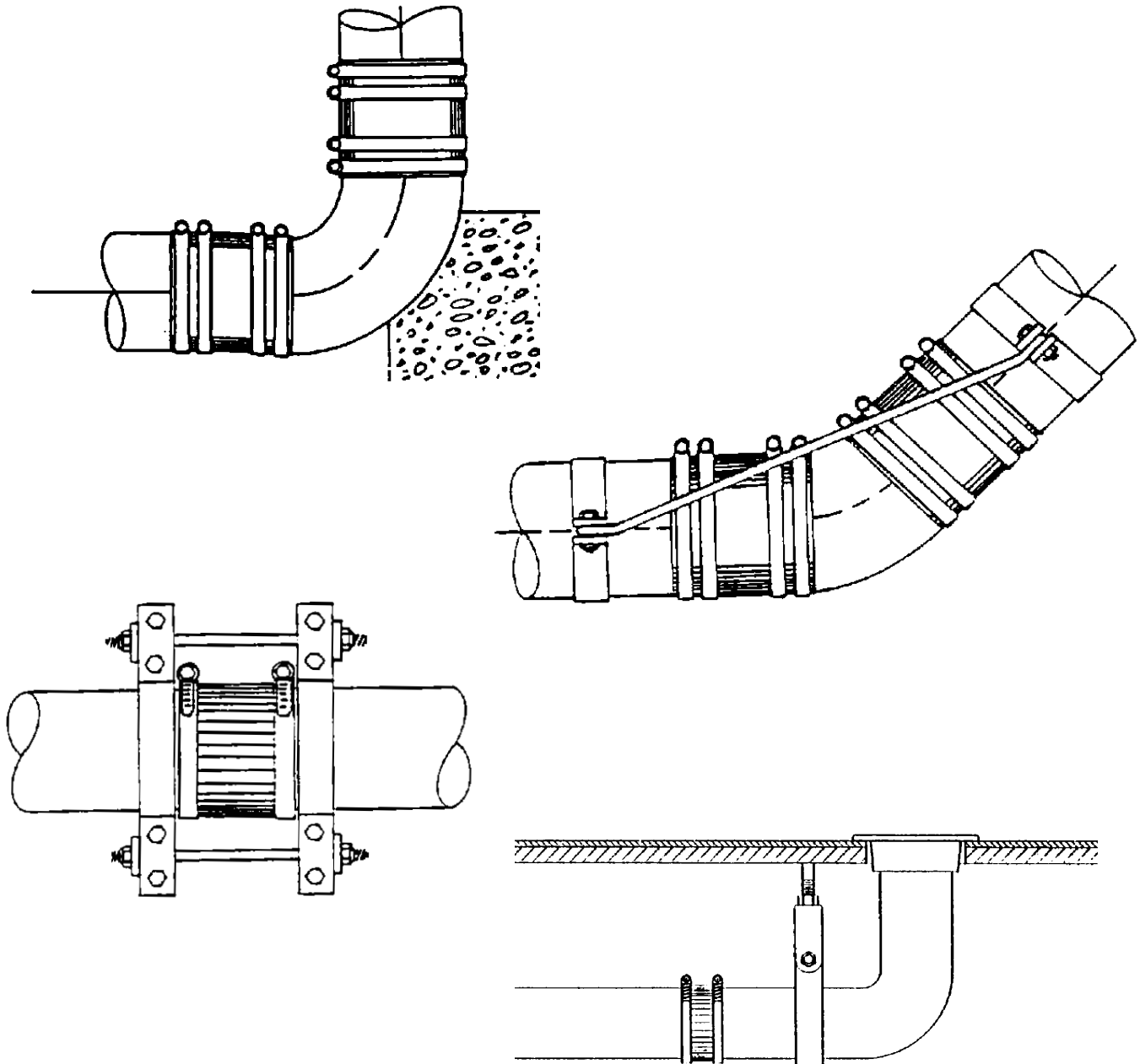

GENERAL INSTALLATION INSTRUCTIONS

A. Vertical Piping:

- 1) Secure vertical piping at sufficiently close intervals to keep the pipe in alignment and to support the weight of the pipe and its contents. Support stacks at their bases and at sufficient floor intervals to meet the requirements of local codes. Approved metal clamps or hangers should be used for this purpose.
- 2) If vertical piping is to stand free of any support or if no structural element is available for support and stability during construction, secure the piping in its proper position by means of adequate stakes or braces fastened to the pipe.

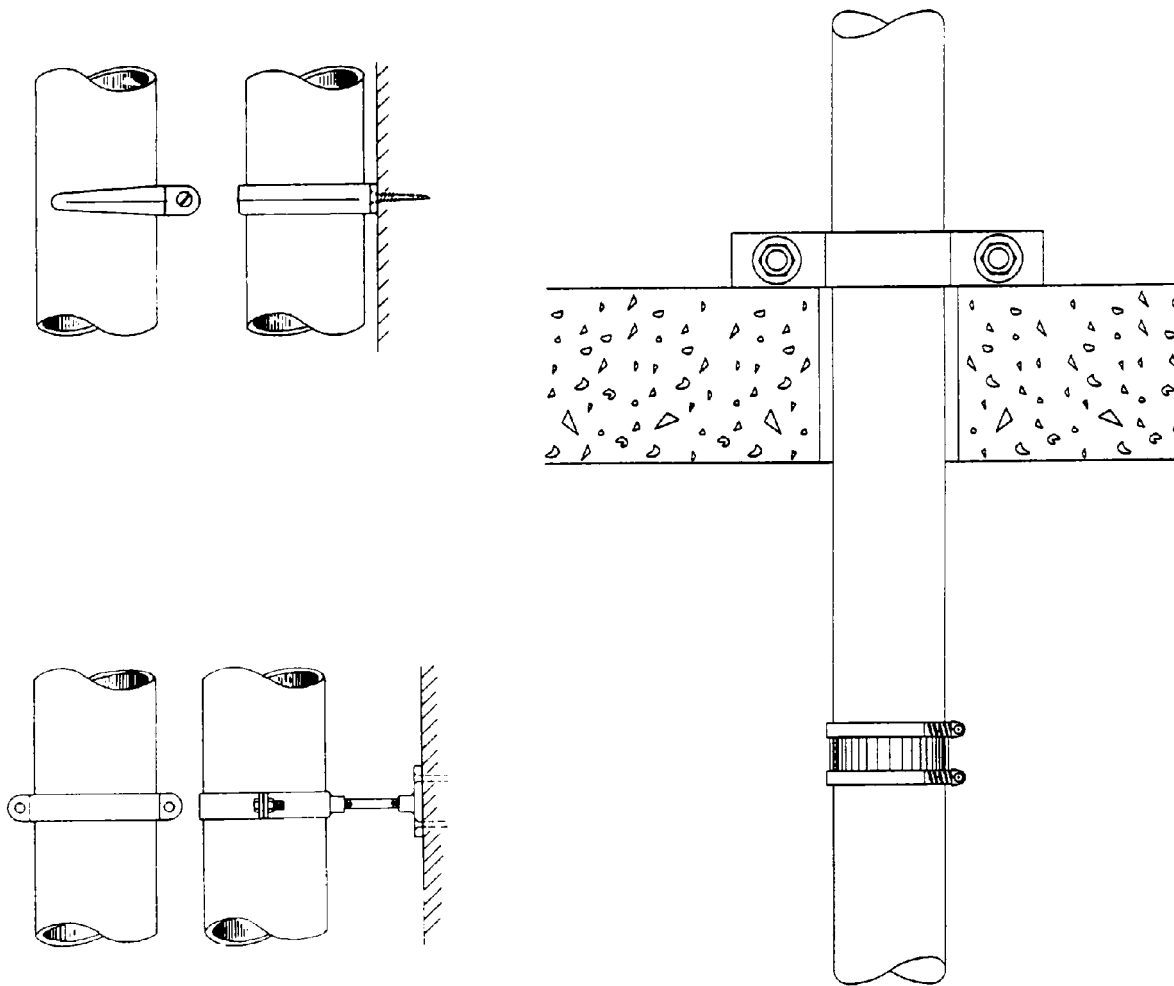

B. *Horizontal Piping, Suspended :*

- 1) Support horizontal piping and fittings at sufficiently close intervals to maintain alignment and prevent sagging or grade reversal. Support each length of pipe by an approved hanger located not more than 18 in. from the joint. For 12 in. and 15 in. hubless pipe, hangers shall be placed on both sides of the coupling when installing full 10-ft lengths.
- 2) Support terminal ends of all horizontal runs or branches and each change of direction or alignment with an approved hanger.
- 3) Closet bends installed above ground should be firmly secured.

C. *Horizontal Piping, Underground :*

- 1) To maintain proper alignment during backfilling, stabilize the pipe in proper position by partial backfilling and cradling.
- 2) Piping laid on grade should be adequately secured to prevent misalignment when the slab is poured.
- 3) Closet bends installed under slabs should be adequately secured.

D. *Installation Inside the Building:*

- 1) Installation Suggestions—According to most authorities and plumbing codes, it is sufficient to support horizontal pipe at each joint, that is, 5-ft pipe should be supported at 5-ft intervals, 10-ft in length may be supported at 10-ft intervals. Supports should be adequate to maintain alignment and prevent sagging and should be placed within 18 in. of the joint.

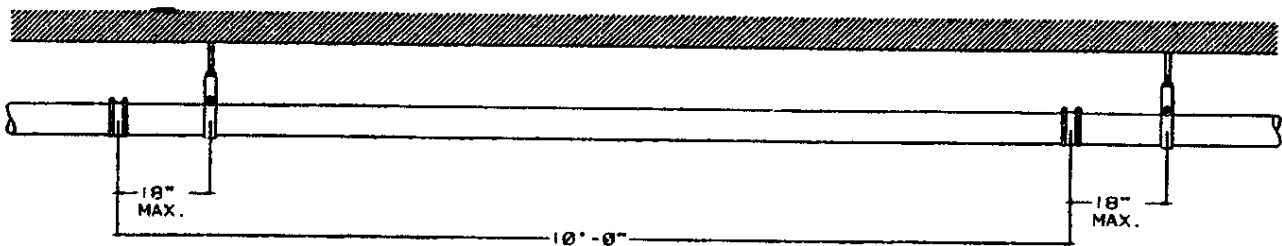

NOTE: For 12 in. and 15 in. hubless pipe, hangers shall be placed on both sides of the coupling when installing full 10-ft lengths.

When the system is filled with water, sufficient beam strength is provided by cast iron soil pipe to carry the load with hangers every ten feet. Any of the horizontal supports or clamps illustrated in Figures 1 and 2 may be used, depending on conditions or what is regarded as essential by the contractor, architect or engineer. Whatever method of support or clamp is used for the horizontal line, care should be exercised to make certain that the line has a proper grade (1/4 in. or more per foot).

Hangers may be fastened to wood members or beams with wood screws, lag screws or large nails. For fastening to "I" beams, bar joists, junior beams or other structural members, beam clamps or "C" clamps may be used. Fasteners for masonry walls may be expansion bolts or screws, or where a void is present, the toggle bolt may be used. Studs shot into the masonry by the explosion method may also be used. Along a wall, a bracket made of structural members or a cast bracket may be used.

Adequate provision should be made to prevent "shear." Where components are suspended in excess of eighteen (18) in. by means of non-rigid hangers they should be suitably braced against movement horizontally, often called sway bracing. Examples of sway bracing are illustrated in Figures 3 and 4.

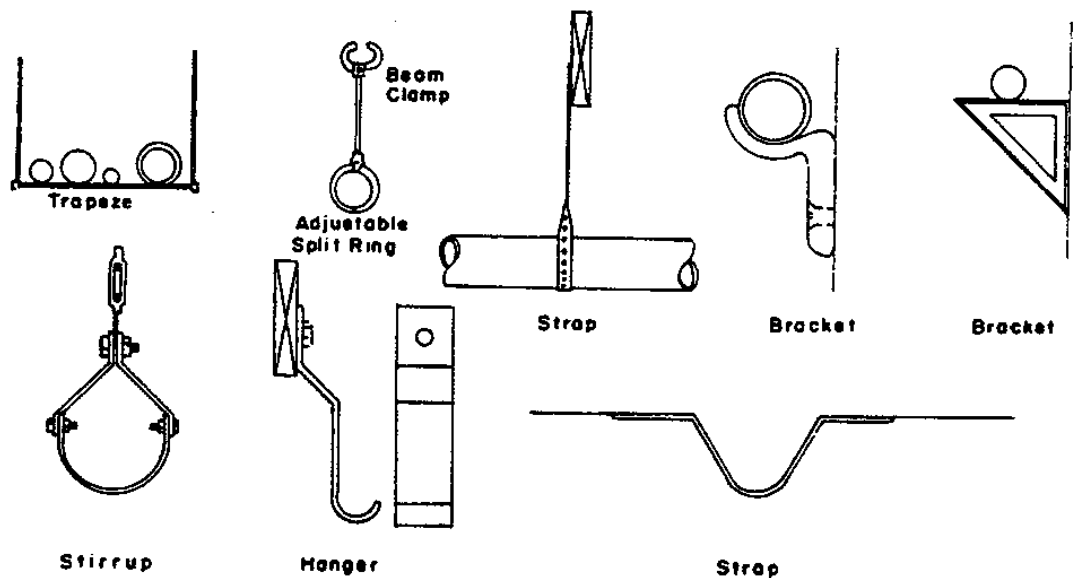

FIGURE 1 – HORIZONTAL PIPE SUPPORTS

Horizontal Installation of Large Diameter Pipe:

Horizontal pipe and fittings five (5) in. and larger must be suitably restrained to prevent horizontal movement. This must be done at every branch opening or change of direction by the use of braces, blocks, rodding or other suitable method, to prevent movement or joint separation. Figure 5 illustrates several methods of restraint.

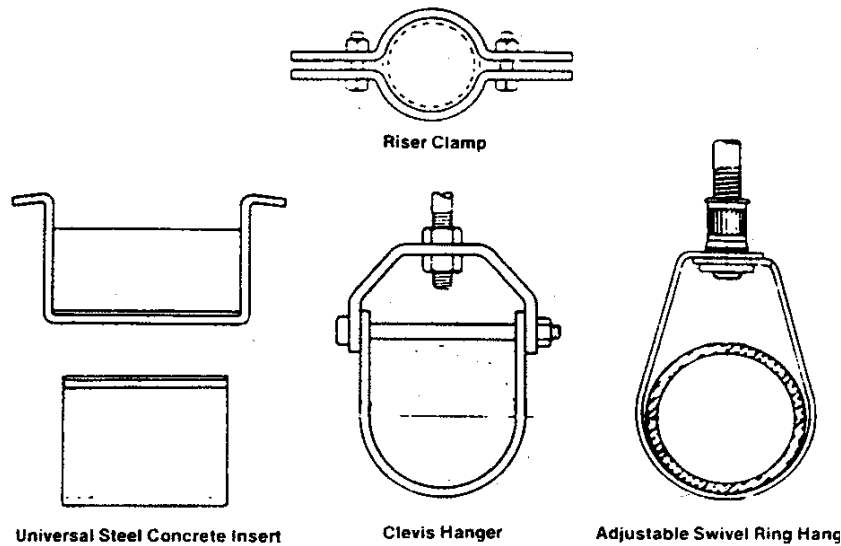

FIGURE 2 – HORIZONTAL PIPE SUPPORTS (Continued)

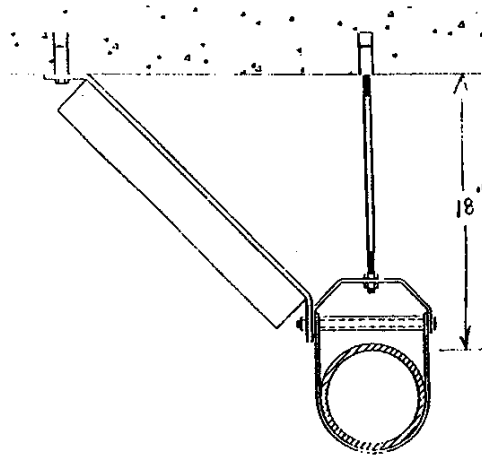

FIGURE 3 – HORIZONTAL PIPE WITH SWAY BRACE

Suggested Installation of Horizontal Fittings:

- a) Hangers should be provided as necessary to provide alignment and grade. Hangers should be provided at each horizontal branch connection. Hangers should be adequate to maintain alignment and prevent sagging and should be placed adjacent to the coupling. By placing the hangers properly, the proper grade will be maintained. Adequate provision should be made to prevent shear. Where pipe and fittings are suspended in excess of eighteen inches by means of non-rigid hangers they should be suitably braced against movement horizontally, often called sway bracing. Refer to Figures 3 and 4 for illustrations.
- b) Closet bends, traps, trap-arms and similar branches must be firmly secured against movement in any direction. Closet bends installed above ground should be stabilized. Where vertical closet studs are used they must be stabilized against horizontal or vertical movement. In Figures 6 and 7, see illustration for strapping a closet bend under a sub-floor and how a clevis type hanger has been used to an advantage.
- c) When a hubless blind plug is used for a required cleanout, the complete coupling and plug must be accessible for removal and replacement.
- d) The connection of closet rings, floor and shower drains and similar “slip-over” fittings and the connection of hubless pipe and fittings to soil pipe hubs may be accomplished by the use of caulked lead and oakum or compression joints.

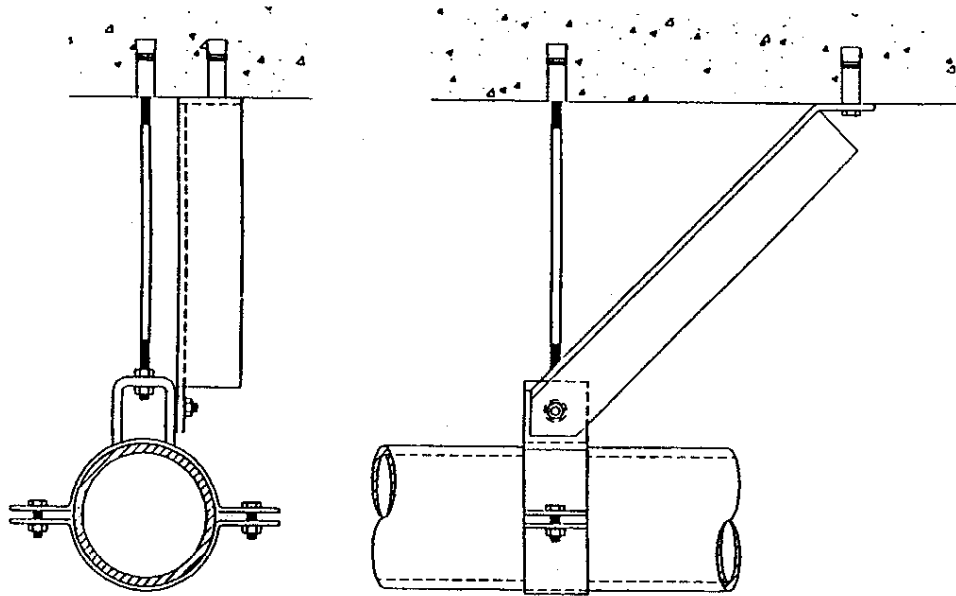

FIGURE 4 – SWAY BRACE

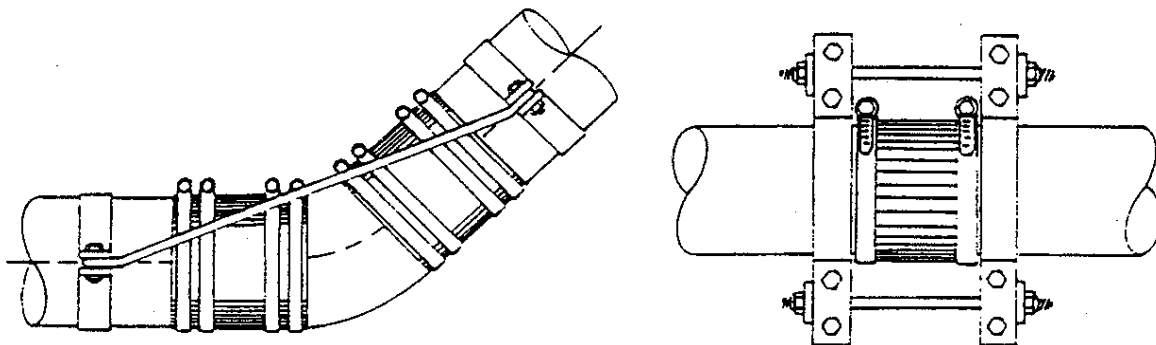
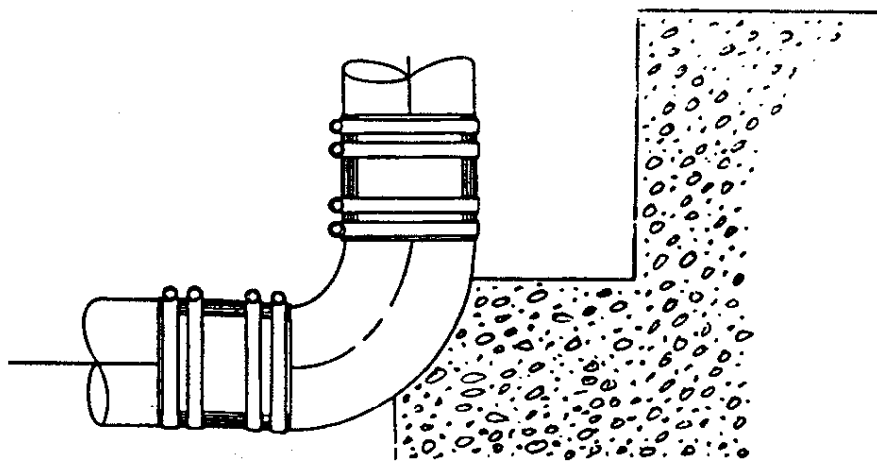

FIGURE 5 – LARGE DIAMETER PIPE

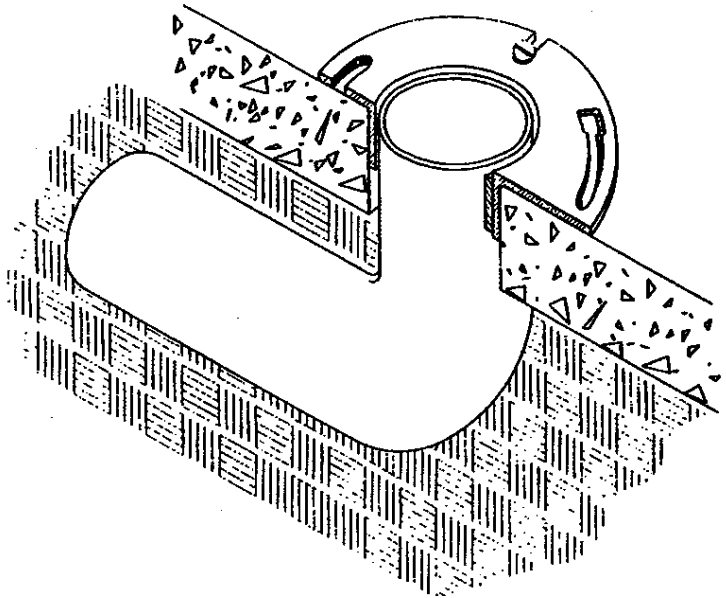

FIGURE 6 – CROSS SECTION VIEW OF CLOSET BEND SHOWING FLANGE PROPERLY SECURED

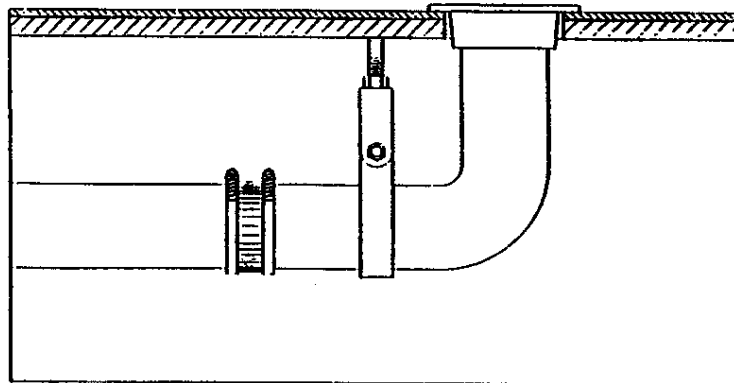

FIGURE 7 – METHOD OF USING HANGER FOR CLOSET BEND

Seismic Restraints:

The following recommendations are some of the factors to consider when installing cast iron pipe in seismically active areas. All installations must comply with local codes and instructions of architects or engineers who are responsible for the piping design.

- A. Brace all pipe 2 in. and larger.

Exceptions:

Seismic braces may be omitted when the top of the pipe is suspended 12 in. or less from the supporting structure member and the pipe is suspended by an individual hanger.

B. Vertical Piping Attachment—

Vertical piping shall be secured at sufficiently close intervals to keep the pipe in alignment and carry the weight of the pipe and contents. Stacks shall be supported at their bases and if over two stories in height at each floor by approved floor clamps. At vertical pipe risers, whenever possible, support the weight of the riser at a point or points above the center of gravity of the riser. Provide lateral guides at the top and bottom of the riser, and at intermediate points not to exceed 30 ft-0 in. on center.

C. Horizontal Piping Supports—

Horizontal piping shall be supported at sufficiently close intervals to prevent sagging. Trapeze hangers may be used. Pipe, where top of the pipe is 12 in. or more from supporting structure shall be braced on each side of a change of direction of 90° or more.

D. Traverse Bracing—

40 ft-0 in. o.c. maximum spacing unless otherwise noted. One pipe section may act as longitudinal bracing for the pipe section connected perpendicular to it, if the bracing is installed with 24 in. of the elbow or tee of similar size.

E. Longitudinal Bracing—

80 ft-0 in. o.c. maximum spacing unless otherwise noted.

F. Miscellaneous—

Provide large enough pipe sleeves through walls or floors to allow for anticipated differential movements.

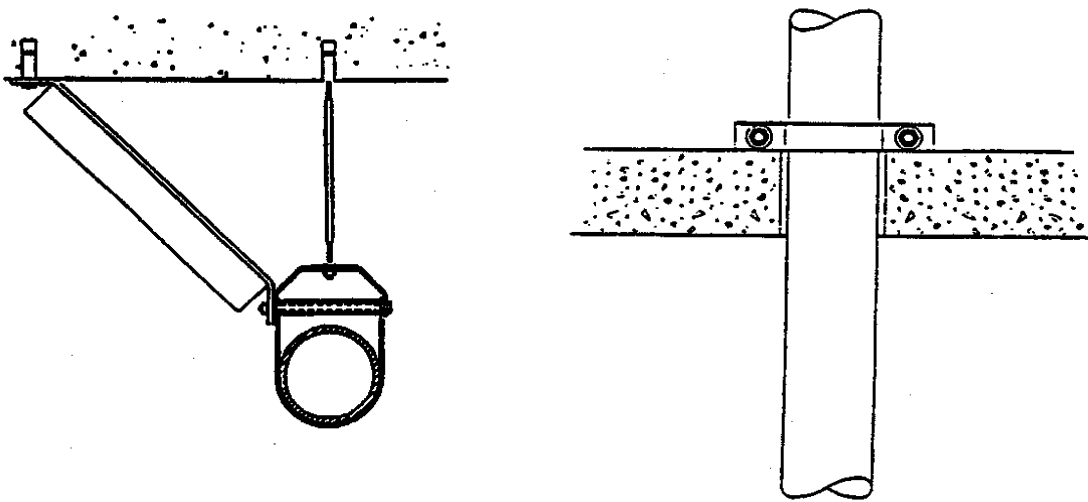

WHERE MULTIPLE SHIELD AND CLAMP JOINTS OCCUR IN A CLOSELY SPACED ASSEMBLY (THAT IS, FITTING FITTING-FITTING, ETC.) A 16 GAUGE HALF SLEEVE MAY BE INSTALLED UNDER THE ASSEMBLY WITH A PIPE HANGER AT EACH END OF THE SLEEVE.

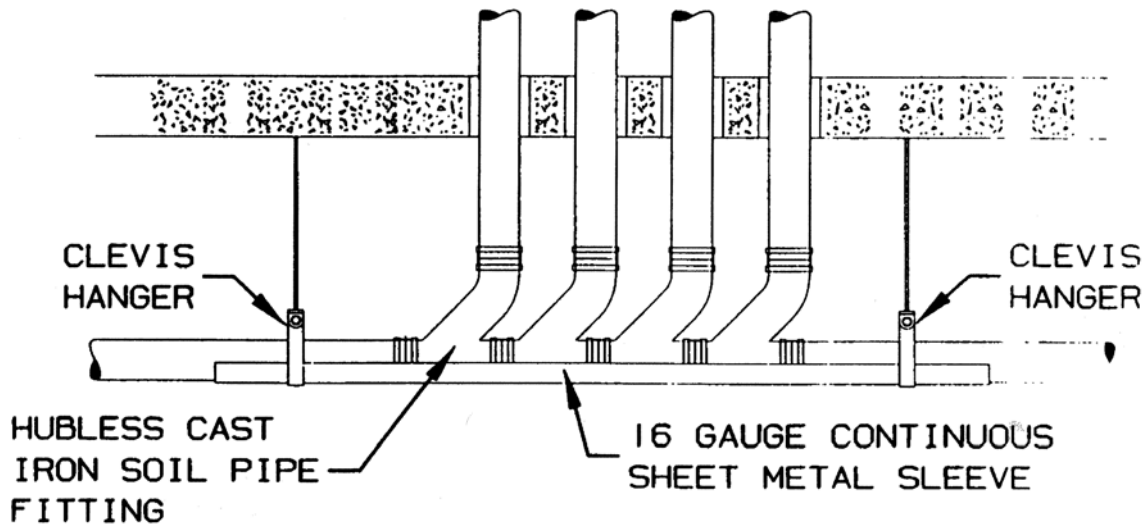

METHOD OF SUPPORTING "MULTI-FITTING" INSTALLATIONS
(HANGER SPACING 10 ft. MAX.)

FIGURE 8 – FOR SEISMIC BRACING ONLY

NOTE: SEISMIC BRACES MAY BE INSTALLED AT EITHER HANGER, BRACES AT BOTH HANGERS ARE NOT REQUIRED.

¹ Reprinted with permission of the Plumbing & Piping Industry Council, Inc.

Vertical Piping:

Vertical components should be secured at each stack base and at sufficiently close intervals to keep the system in alignment and to adequately support the weight of the pipe and its contents. Floor clamps, sometimes called friction clamps, are required for vertical piping in multi-story structures in order for each floor to carry its share of the load. Figures 9 and 10 show some typical brackets or braces for vertical piping. Figure 11 shows a method of clamping the pipe at each floor, using a friction or floor clamp.

If vertical piping is to stand free of any support or if no structural element is available for support and stability during construction, secure the piping in its proper position by means of adequate metal stakes or braces fastened to the pipe.

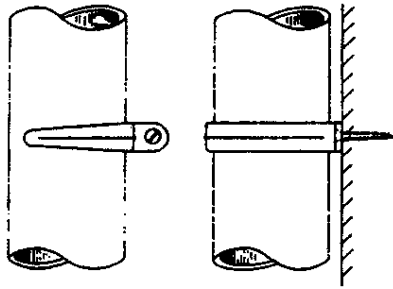

FIGURE 9 — BRACKET FOR
VERTICAL PIPE

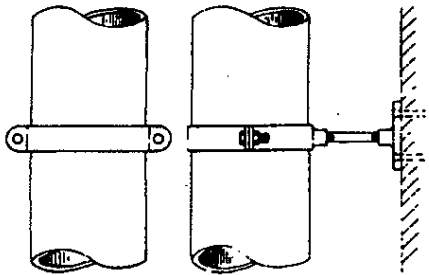

FIGURE 10 — ONE HOLE STRAP FOR
VERTICAL PIPE

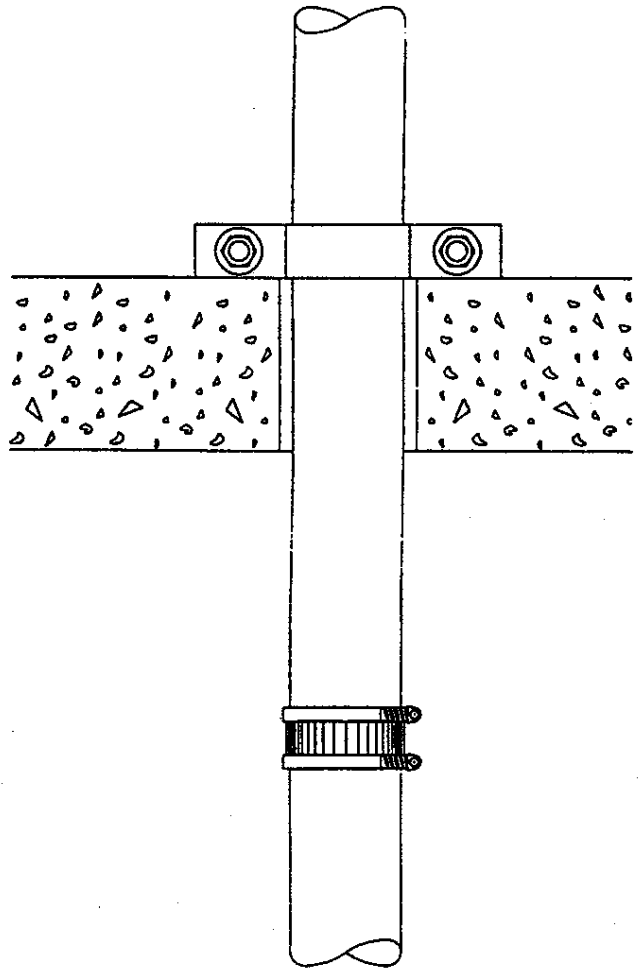

FIGURE 11 — METHOD OF CLAMPING
THE PIPE AT EACH FLOOR,
USING A FRICTION CLAMP
OR FLOOR CLAMP

Testing and Inspection

Once the roughing-in is completed on a cast iron piping project, it is important to test and inspect all piping for leaks. The installer usually is required to notify the plumbing inspector of the administrative authority having jurisdiction over plumbing work before the tests are made. Concealed work should remain uncovered until the required tests are made and approved. When testing, the system should be properly restrained at all bends, changes of direction, and ends of runs.

There are various types of tests used for the installed cast iron soil pipe and fittings. These are *water or hydrostatic, air, smoke and peppermint*. Proper safety procedures and protective equipment should be employed during all testing procedures. Installers should always consider local conditions, codes, manufacturer installation instructions, and architect/engineer instructions in any installation.

A water test, also called a hydrostatic test, is made of all parts of the drainage system before the pipe is concealed or fixtures are in place. This test is the most representative of operating conditions of the system. Tests of this type may be made in sections on large projects. After all air is expelled, all parts of the system are subjected to 10-ft of hydrostatic pressure (4.3 psi) and checked for leaks.

Test Procedures:

Water Test - A water or hydrostatic test is the most common of all tests used to inspect a completed cast iron soil pipe installation. The purpose of the test is to locate any leaks at the joints and correct these prior to putting the system in service. Since it is important to be able to visually inspect the joints, water tests should be conducted prior to the "closing in" of the piping or back fill of the underground piping.

As water fills a vertical cylinder or vertical pipe it creates hydrostatic pressure. The pressure increases as the height of water in the vertical pipe increases. The Cast Iron Soil Pipe Institute recommends 10-ft of hydrostatic pressure (4.3 psi). This is the recommended test by most plumbing codes. To isolate each floor or section being tested, test plugs are inserted through test tees installed in the stacks. All other openings should be plugged or capped with test plugs or test caps (see Figure 12).

Prior to the beginning of the test, all bends, changes of direction and ends of runs should be properly restrained. During the test, thrust forces are exerted at these locations. Thrust is equal to the hydrostatic pressure multiplied by area. Thrust pressures, if not restrained, will result in joint movement or separation causing failure of the test. All air entrapped in the system should be expelled prior to beginning the tests.

Once the stack is filled to ten feet, an inspector makes a visual inspection of the section being tested to check for joint leaks. In most cases, where these leaks are found, hubless couplings have not been torqued to the recommended 60 lbf-in. or for couplings requiring higher torque improper torquing occurred. Proper torquing will correct the problem.

Fifteen minutes is a suitable time for the water test. Once the system has been successfully tested it should be drained and the next section should be prepared for test.

Thrust Forces:

Thrust or displacement forces are encountered as the pipe or cylinder is filled with water. The higher the fill the greater the force acting to separate a joint. The Thrust Table shows the pounds of force tending to cause joint separation when using pipe from 1 ½" to 15" and a head of water from 10' to 120'.

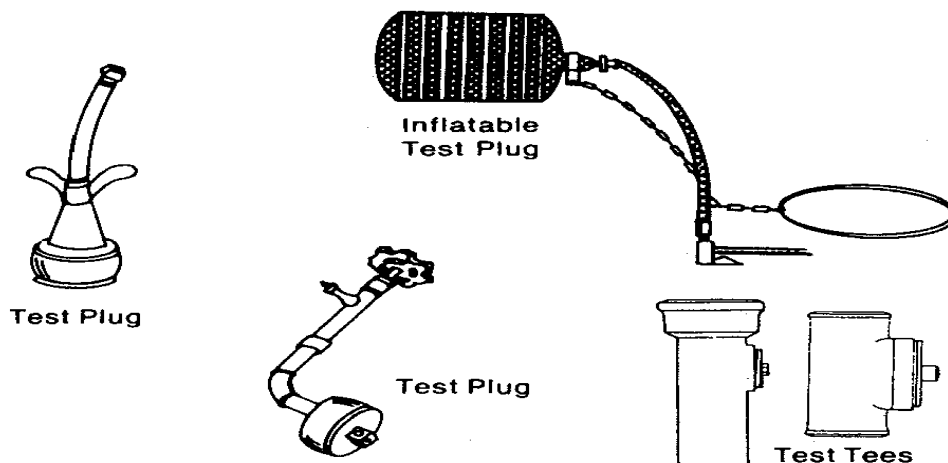

FIGURE. 12 –ILLUSTRATION OF TEST PLUGS AND TEST TEES

THURST TABLE

Thrust or Displacement Forces Encountered in Hydrostatic Testing of Hubless Cast Iron Soil Pipe

Pipe Size, in.		1 1/2	2	3	4	5	6	8	10	12	15
HEAD, feet of water	Pressure, psi	Thrust, lb	Thrust, lb	Thrust, lb	Thrust, lb	Thrust, lb	Thrust, lb	Thrust, lb	Thrust, lb	Thrust, lb	Thrust, lb
10	4.3	12	19	38	65	95	134	237	377	538	847
20	8.7	25	38	77	131	192	271	480	762	1088	1714
30	13.0	37	56	115	196	287	405	717	1139	1626	2562
40	17.3	49	75	152	261	382	539	954	1515	2164	3409
50	21.7	62	94	191	327	479	676	1197	1900	2714	4276
60	26.0	74	113	229	392	574	810	1434	2277	3252	5124
70	30.3	86	132	267	457	668	944	1671	2654	3790	5971
80	34.7	99	151	306	523	765	1082	1914	3039	4340	6838
90	39.0	111	169	344	588	860	1216	2151	3416	4878	7685
100	43.4	123	188	382	654	957	1353	2394	3801	5429	8552
110	47.7	135	208	420	719	1052	1487	2631	4178	5967	9400
120	52.0	147	226	458	784	1147	1621	2868	4554	6505	10247
Area, OD in. ²		2.84	4.34	8.81	15.07	22.06	31.17	55.15	87.58	125.09	197.06

^AThrust = Pressure × Area.

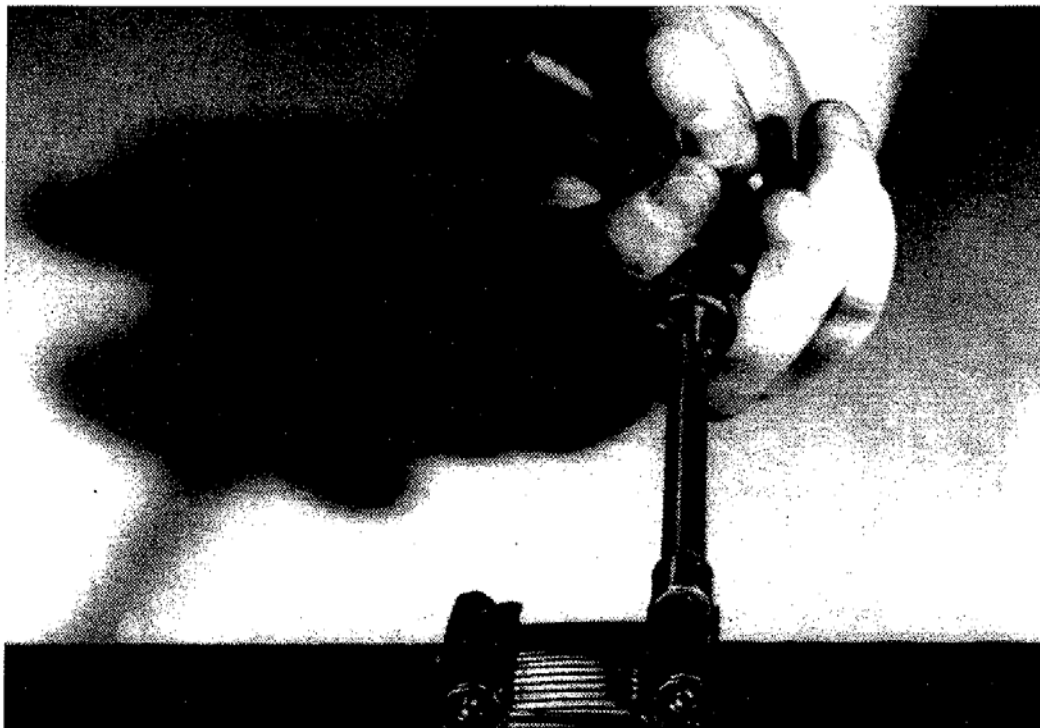
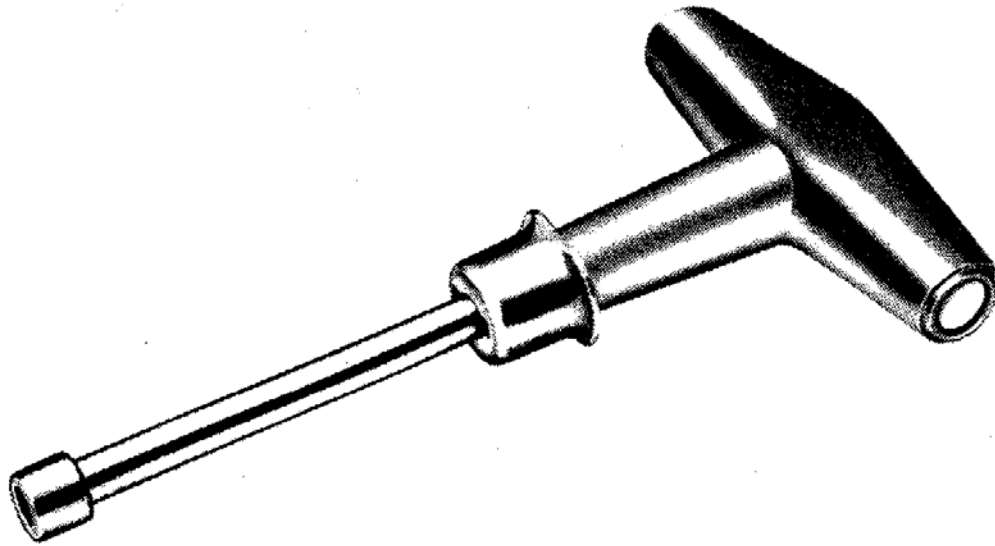

Typical manually operated 60 inch pound torque wrenches used for coupling assembly.



Typical power operated torque tools used for coupling assembly.

